

MatriX 450-serie



40011653-1728 MatriX 450 ENG

 **faber**

Installation Instructions

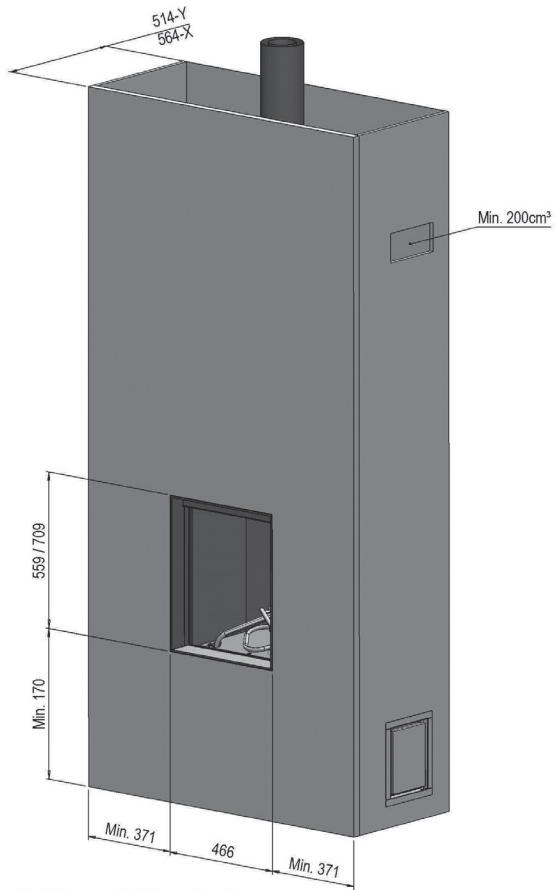

Y = thickness material (max. 50mm)
X = thickness material (max. 100mm)

1.0

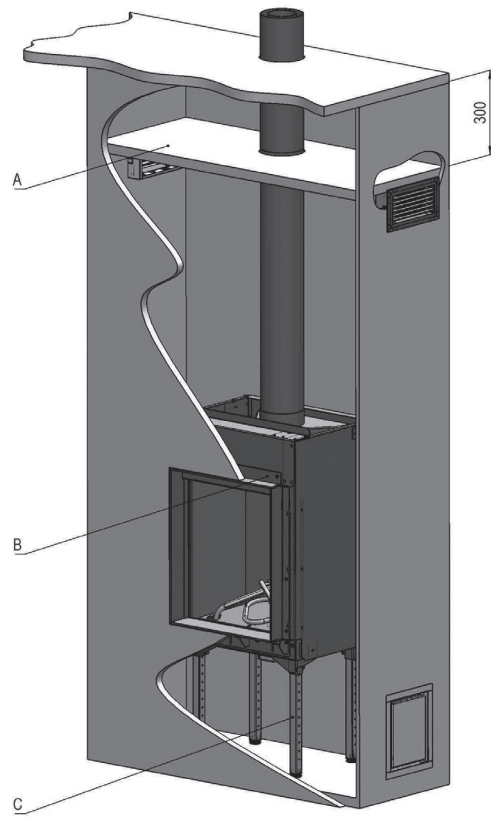

1.1

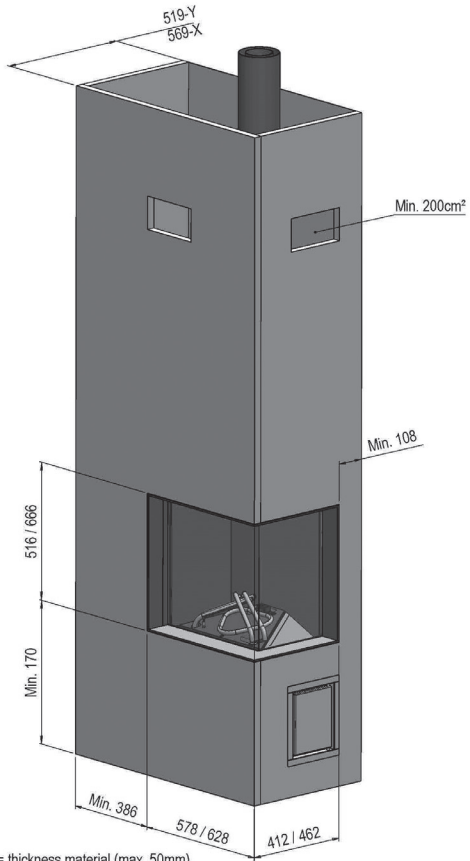

Y = thickness material (max. 50mm)
X = thickness material (max. 100mm)

1.2

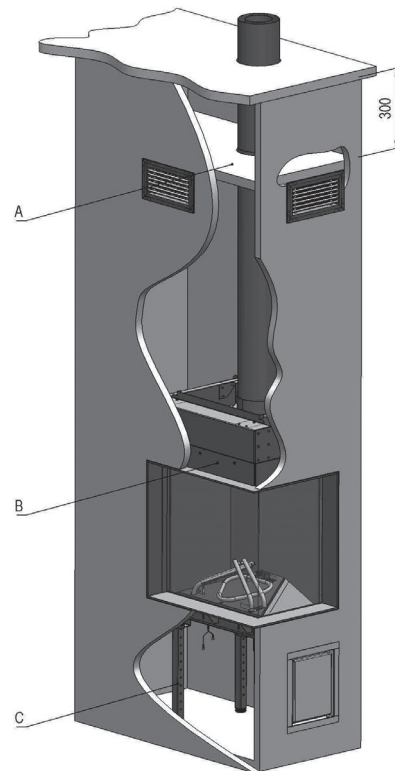

1.3

Installation Instructions

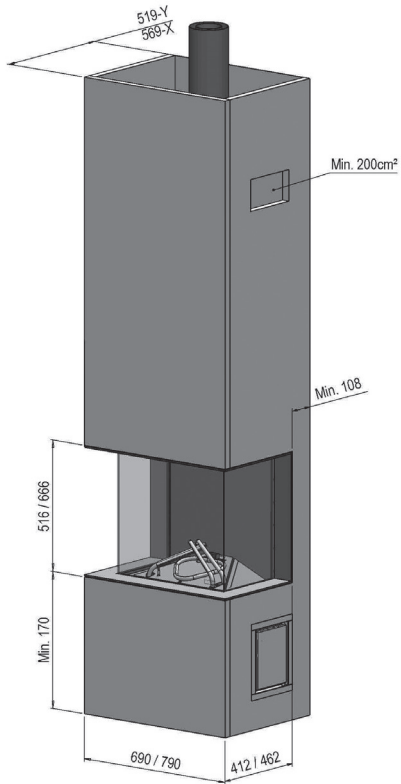

Y = thickness material (max. 50mm)
X = thickness material (max. 100mm)

1.4

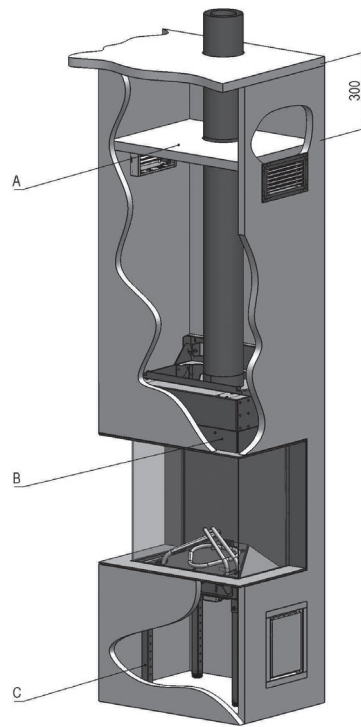

1.5

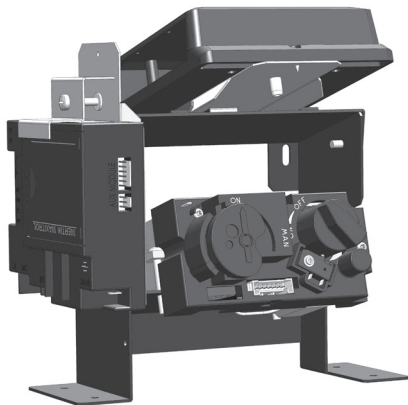

1.6



1.7

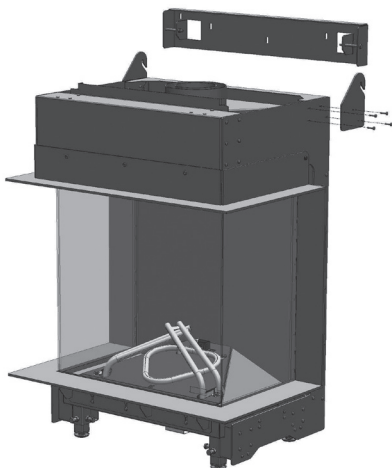

1.8

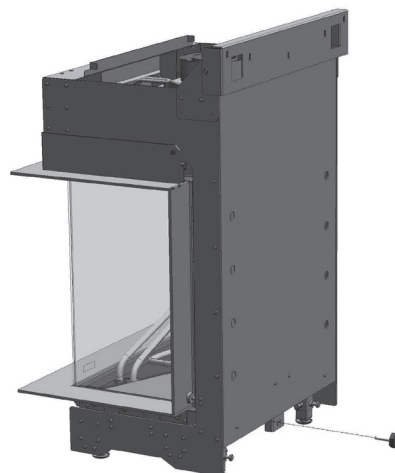

Installation Instructions



1.9

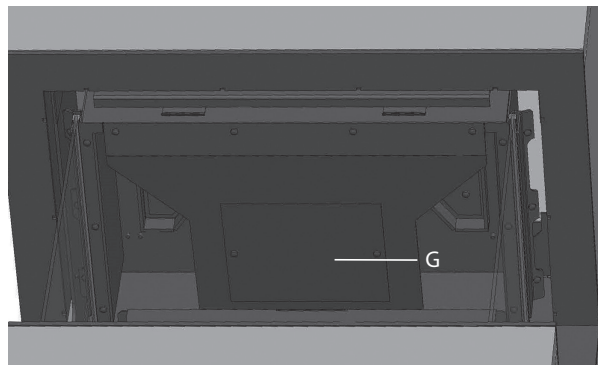
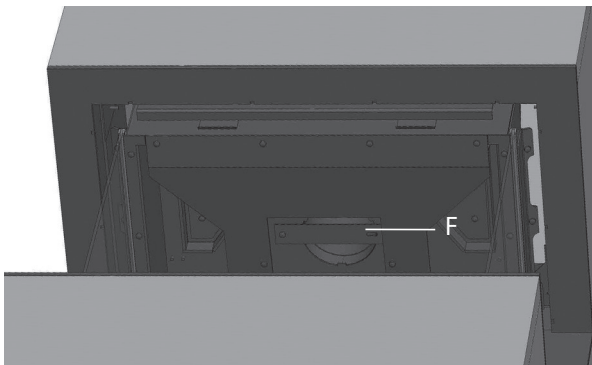

2.0

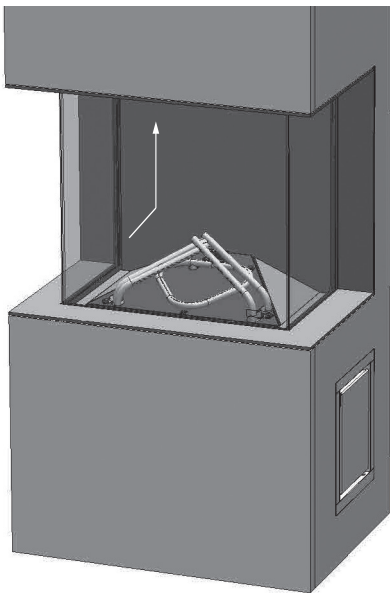

2.1

Installation Instructions

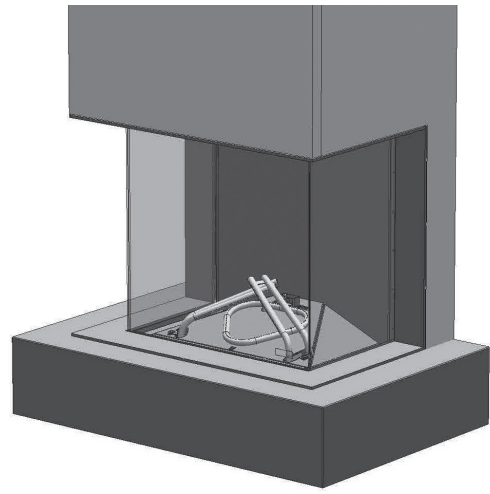
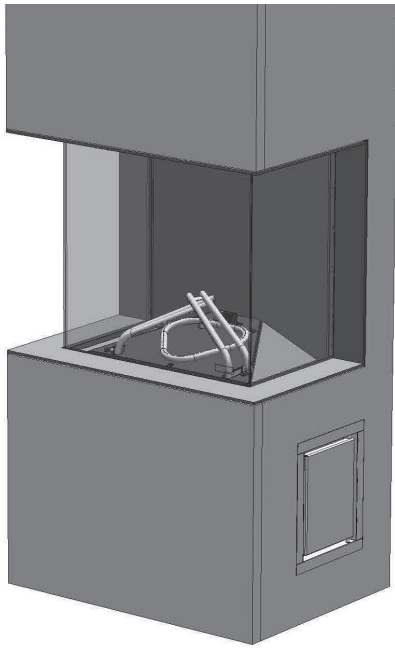

2.2

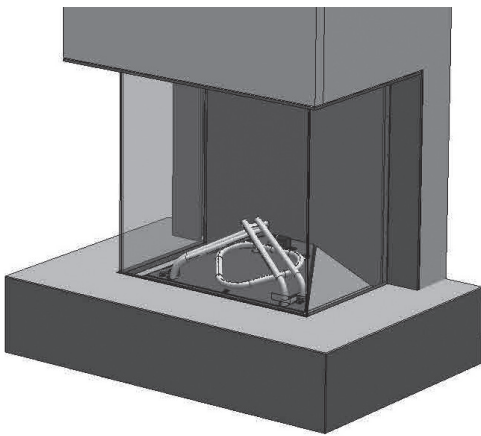

2.3

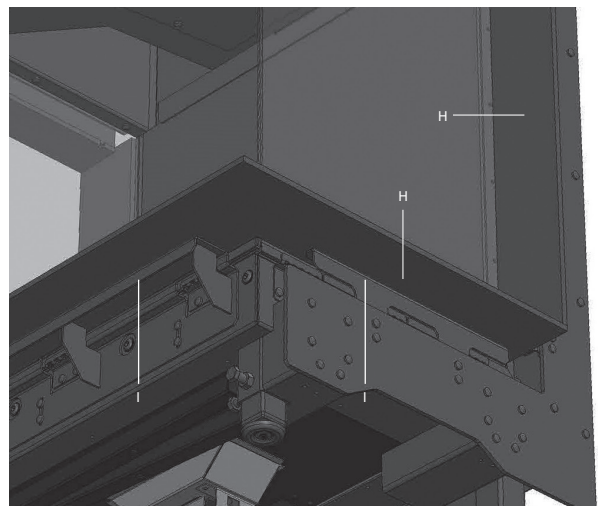

2.4

Installation Instructions

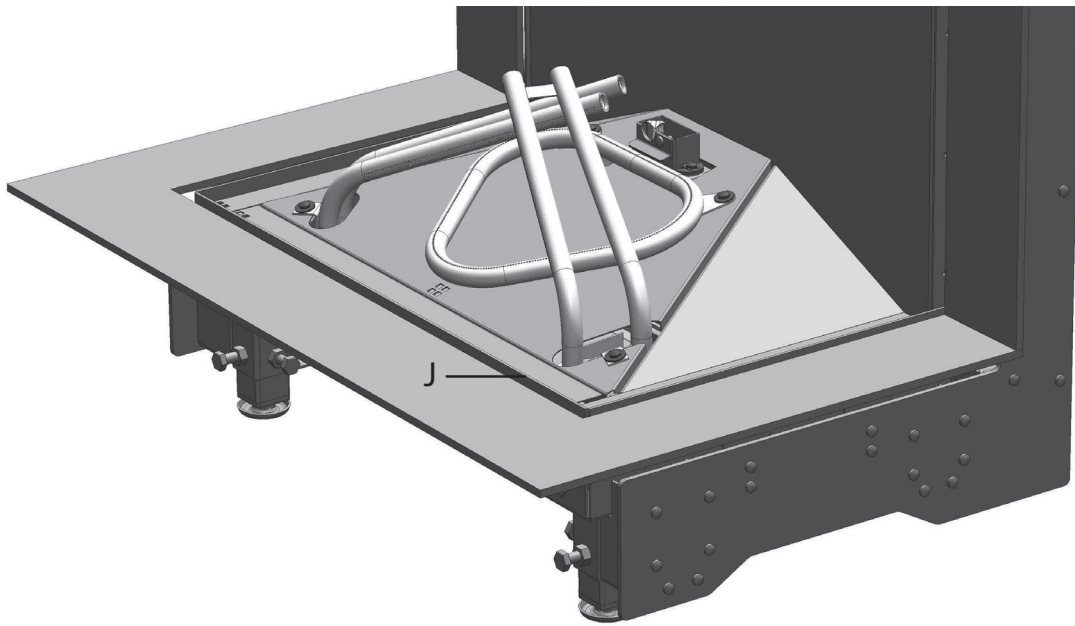

2.5

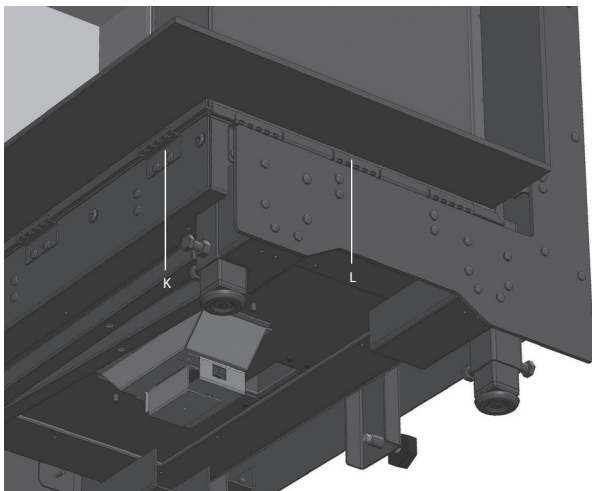

2.6

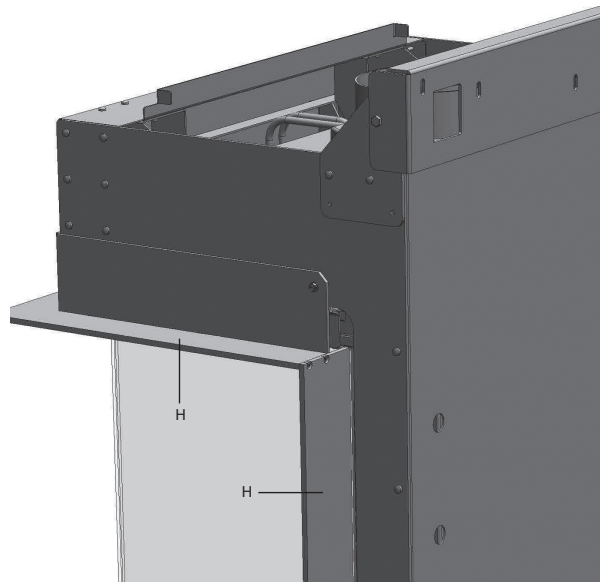

2.7

Installation Instructions

Wire diagram I.T.C.

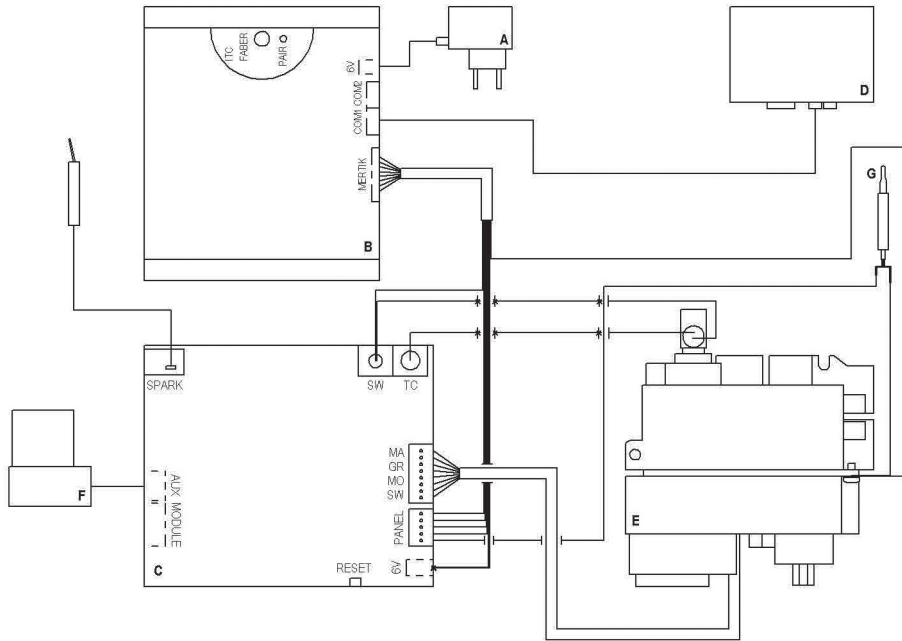

2.8

Wire diagram Symax

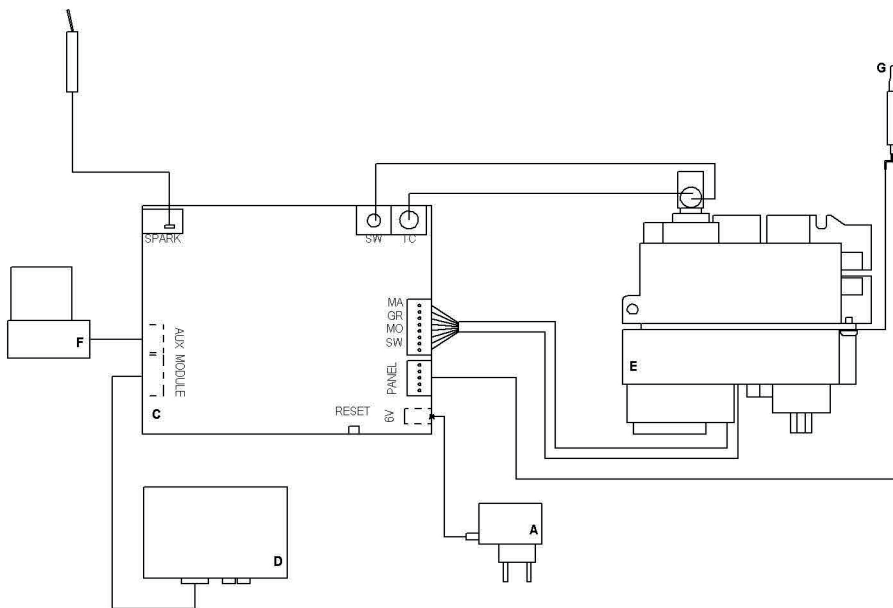

2.9

Installation Instructions

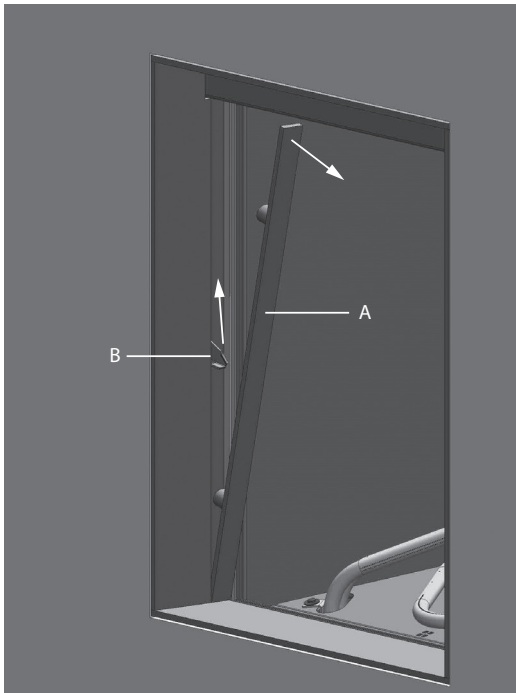

3.0



3.1



3.2

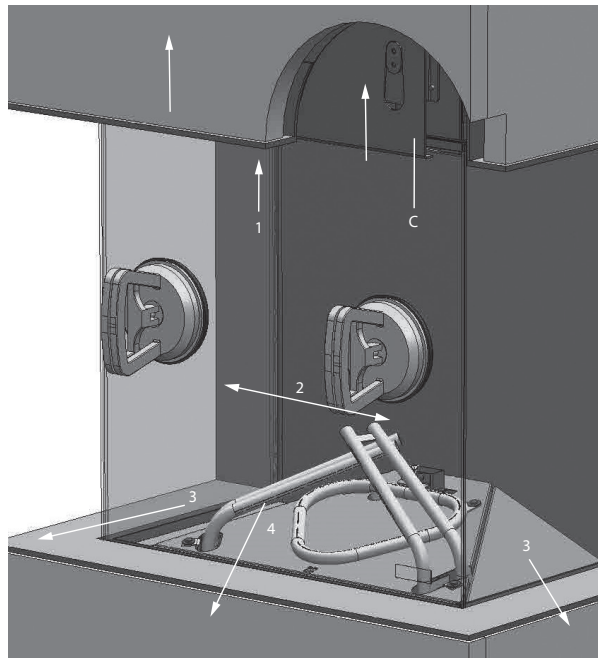

3.3

Installation Instructions

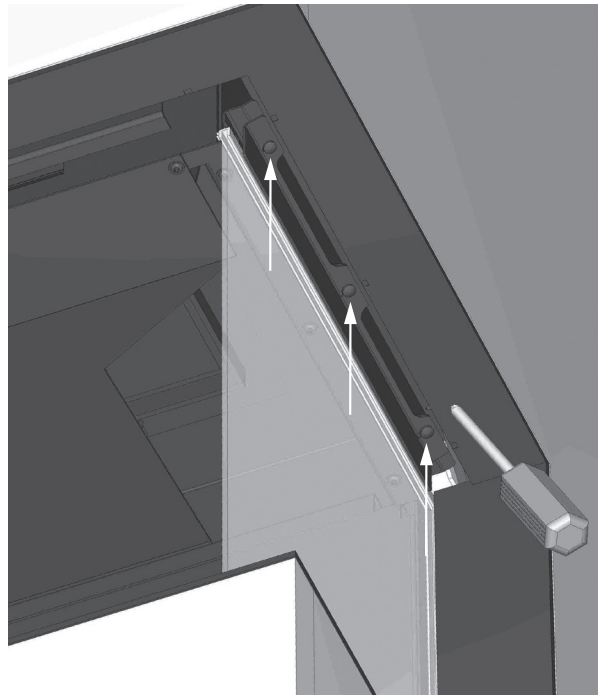
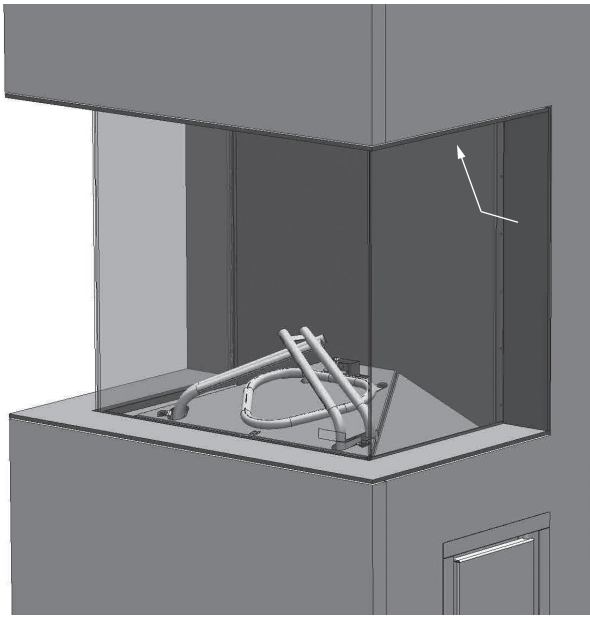

3.4

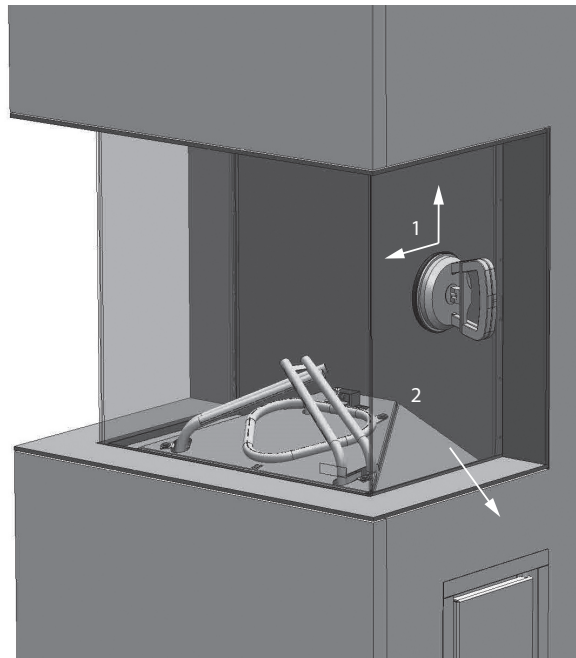

3.5

Installation Instructions

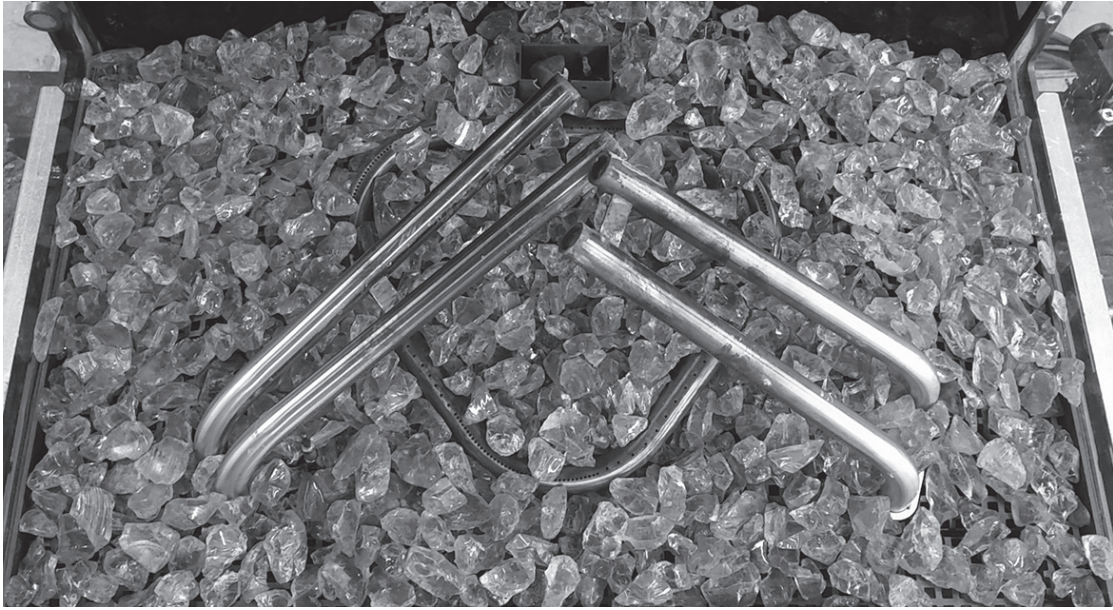

4.0

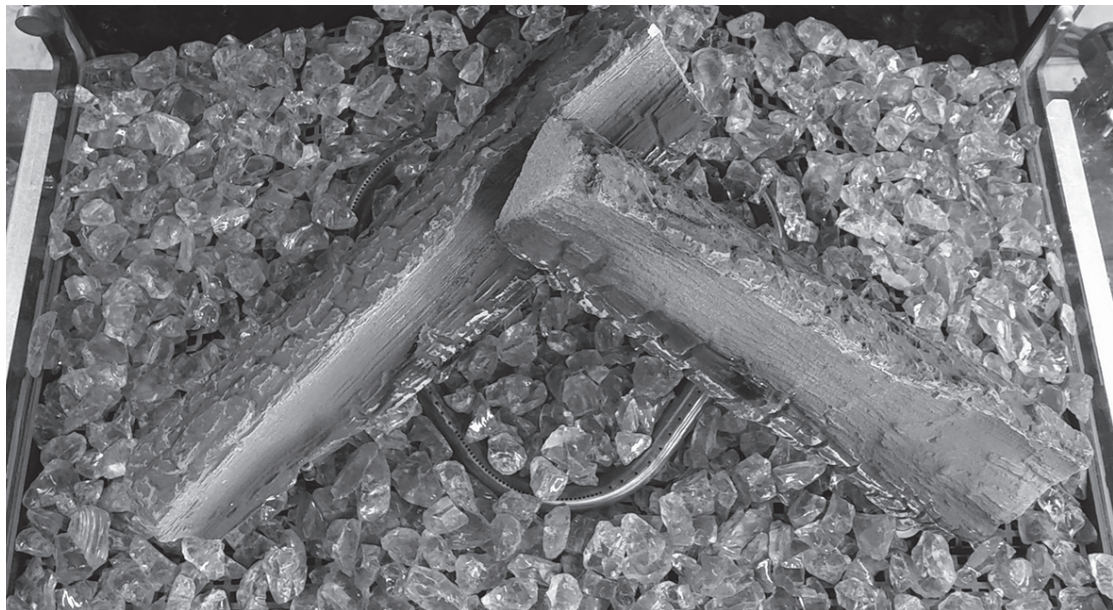

4.1

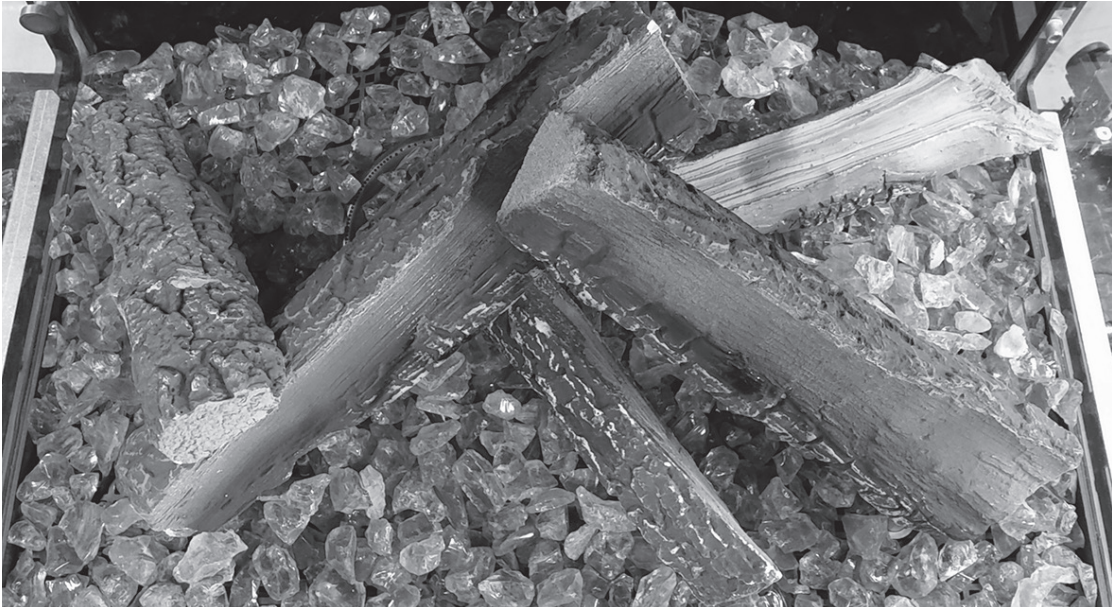

4.2



4.3

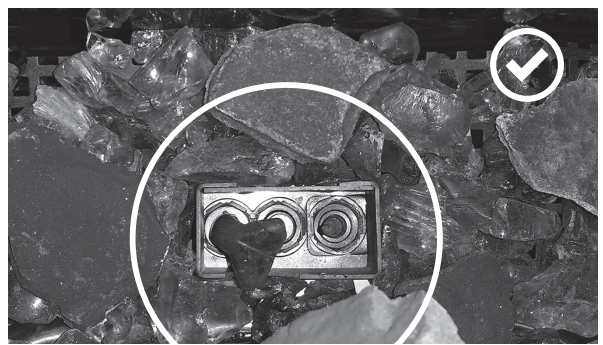
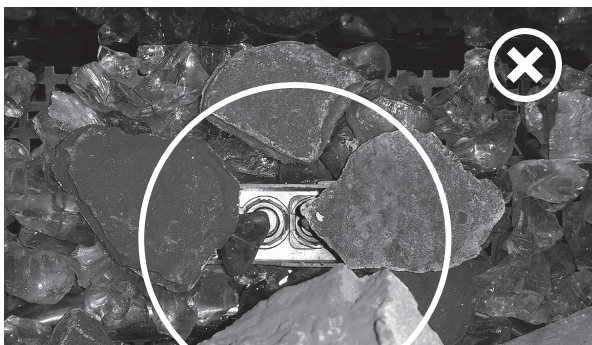

4.4

1 Dear user

Congratulations on purchasing your Faber product, a quality product that will provide you with the warmth and atmosphere for many years. Please read the user manual before using the fire. Should a malfunction occur despite the careful final checks, then you can always contact your Faber dealer.

Please note:

The data of your fire is available in the user manual.

1.1 Introduction

Only have the appliance installed by a qualified installer according to the gas safety regulations.

Read this installation manual properly.

1.2 Please check

Check the fire for transport damage and report any damage immediately to your dealer.

1.3 CE Declaration

Glen Dimplex Benelux certifies that this Faber fire complies with the essential requirements of the gas appliances directive.

Product: gas room heater

Model: MatriX 450/500-I/II/IIR/III

MatriX 450/650-I/II/IIR/III

Applicable EC directives: 90/396/EEC

Harmonized standards applied: NEN EN 613:2000 and NEN EN 613/A1:2003

This declaration is invalid, if without the written permission of Glen Dimplex Benelux:

- Changes are made to the appliance.
- The fire is connected to other exhaust materials than specified.

2 Safety instructions

- The unit must be installed and subsequently serviced every year and maintained in accordance with these instructions and the applicable national and local regulations.
- Ensure that the data on the type label matches the local gas type and pressure.
- The settings and the construction of the fire must not be changed!
- Do not place extra imitation wood or other smoldering material on the burner or in the combustion chamber.
- The appliance is for atmosphere and heating purposes. This means that all surfaces, including the glass, can be very hot (over 100°C). Exceptions to this are the bottom of the fire and the control elements.
- Do not place any combustible materials within 0,5m of the radiation area of the fire.

- Through the natural air circulation of the fire moisture and uncured volatile components from paint, building materials and carpeted floors, etc. are attracted. These parts can settle as soot on cold surfaces. Therefore do not light the fire shortly after installation.
- Light the fire for the first time and run for several hours on the highest setting, so that the paint can cure. Provide adequate ventilation, so that any fumes can disperse; we recommend vacating the room during this process.

> **Please note:**

1. All transport packaging is removed.
2. No children and pets in the room present.

3 Installation requirements

3.1 Fire

- This device can be built into an existing or new chimney.
- For devices with flexible gas pipes, the gas regulator block is mounted on the right side of the fire for transport reason (fig 1.6). The gas regulator block with the receiver and the I.T.C. must be placed on a distance of max. 30cm behind a service door.
When desired, there are 2 metres burner pipes (To prevent damage to cables and pipes during transport, these are tied together with tie-wraps. Remove it to ensure the proper functioning of the appliance).

3.2 False chimney breast or other structure

- The false chimney should be of non-combustible material.
- The space above the fire should always be ventilated using the supplied grids or a similar alternative with minimal free passage of 200cm² per grid.
- The false chimney breast and its construction may not rest on the appliance.
- It is not permitted to start directly on the device with concentric cut down pipe material.
The air supply could then possibly be closed.

3.3 Flue pipe and terminal requirements

- For the supply of the combustion air and the discharge of the combustion gases you should always use the Flue materials specified by Faber. Only when using these materials can Faber guarantee the safe and proper operation of the appliance.
- The outside of the concentric flue material can heat up to +/-150°C. Ensure, when penetrating a flammable wall or ceiling, construction with proper insulation and protection. And ensure respective distance.
- Ensure for great discharge lengths that the concentric discharge material is supported every 2m, so that the weight of the material is not supported by the fire.
- It is not permitted to start directly on the device with concentric cut down pipe material.
The air supply could then possibly be closed.

3.4 Terminals

The combined supply and discharge can be done both via wall or through the roof or through an existing chimney. Verify if the position of the terminal meets the local regulations regarding ventilation openings.

The flue outlet can end on an external wall or a roof. Check whether the outlet desired by you complies with local requirements concerning good function and ventilation systems.

> **Please note:**

For a proper functioning the terminal should be at least 0,5m. away from:

- Corners of the building
- Roof overhangs and balconies
- Eaves (with the exception of the roof ridge, see Chapter 15)

3.4.1 C11, wall terminal

For a facade or wall outlet use a wall terminal (see fig. 1.9 C11).

Depending on the calculation this can be a diameter of 130/200mm or 100/150mm.

3.4.2 C31, roof terminal

For a flat or pits roof outlet use a long roof outlet with a diameter of 100/150mm (see fig. 1.9 C31).

3.4.3 C91, existing chimney

For an existing chimney use the short chimney outlet with a diameter of 100/150mm (see fig. 1.9 C91).

In this case the existing chimney acts as air inlet an inserted flexible stainless steel pipe discharges the flue gas. The top and the bottom should be airtight.

Depending on the calculated outlet diameter, use a flexible stainless steel tube of Ø100mm or Ø130mm with CE marking for 600°C.

> **Please note:**

The minimum chimney diameter for a 130mm flexible stainless steel pipe must 200x200mm. and for a 100mm flexible stainless steel pipe 150x150mm.

3.5 Existing chimney

You can also connect to an existing fireplace chimney. The existing chimney functions then as air supply and a flexible stainless steel tube drawn through the chimney carries the flue gases. The flexible stainless steel tube of Ø100mm must have a CE mark have up to 600°C.

The chimney must have the following conditions:

- The channel of the chimney must be at least 150x150mm.
- There should be no more than one device on a chimney.
- The chimney must be in good condition:
 - no leakage
 - well cleaned

For more information about connections to existing chimneys, ask the installation manual "chimney connection set".

4 Preparation and installation instructions

4.1 Gas connection

The gas connection must comply with the applicable local standards.

We advise using a Ø 15mm gas connection directly from the gas meter to the appliance, with a shut-off valve in the proximity of the appliance, which must always be freely accessible.

Position the gas connection so that it is easily accessible at all times for service, and that the burner unit can be disassembled.

4.2 Electrical connection

The power supply must comply with the applicable local standards. A wall socket 230VAC/50Hz must be installed near the fire.

For power supply make use of the included plug adapter.

See fig 2.8 or 2.9 for the wiring diagram of this connection and the LED Symbio module.

- A = plug adapter
- B = control unit
- C = receiver
- D = LED Symbio module
- E = control block
- F = magnet valve
- G = 2nd thermocouple

4.2.1 Smart-Home installation

You can connect the control unit to the receiver with an external source, such as a Domotica home automation system, using the 5-wire pin connector.

(Part G60-ZCE/1000, art.no.: 06022950). The total length of the cable may not exceed 8m. Signal relay (gold-plated contacts) or opto-couples are recommended!

4.2.2 Faber ITC (Intelligent Technical Controller)

The ITC gives you more options, such as ECO control, control, error messages, maintenance advice and such.

For further information see the "ITC" user manual.

4.3 Preparing the fire

- Remove the fire from its packaging. Ensure that the gas supply pipes under the appliance are not damaged.
- Remove frame and glass and take the packaged parts from the fire.
- Store frame and glass in a safe place.
- Prepare the gas connection on the regulator.

4.4 Positioning the fire

Take the installation requirements into account (see Chapter 3).

Place the appliance in the right position and set the height with the (optional) leg levelers.

Height adjustment and levelling of the appliance (see point C, fig. 1.1).

Rough height adjustment:

- With the extendable (optional) leg.

Fine adjustment:

- With the adjustable feet.

4.4.1 Hanging on the wall 450/500-650-III, -IIR and -III

The appliance can be wall-mounted with the optional wall bracket (see fig. 1.8).

4.5 Installing the flue materials

- When penetrating a non-combustible wall or ceiling the opening must be at least 5mm larger than the diameter of the discharge material. At a combustible wall or ceiling is this 100mm larger than the diameter of the drainage material.
- Horizontal sections should be installed with a slope towards the fire (3 degrees).
- Build the system from the fire. If this is not possible you can make use of an extendable adapter section.
- For truing up the exhaust system use the 0,5m. pipe, which can be shortened and ensure that the inner pipe is always 2cm longer than the outer pipe.
- Parts, which are shortened, must be secured with a self-tapping screw.
- Wall and roof terminals can also be cut.
- Do not insulate but ventilate built-in flue material (approx. 100cm²).

4.6 Constructing the false chimney

If possible, carry out a performance test at the fire before finally finishing the installation.

4.6.1 False chimney

- * Construct the false chimney of non-combustible material in combination with metal profiles or of masonry/concrete blocks.
- * Be aware of ventilation grids and service door (see fig. 1.0 to 1.5). Place above the ventilation grids a screen plate made of non-combustible material (see fig. 1.1, 1.3 or 1.5)
- * Always use a lintel or reinforcing bars while bricking the outlet. They should not be placed directly on the fire.
- * Built the false chimney against the appliance (see fig. 1.0 to 1.5). Keep a minimum distance of 2mm between the false chimney and the appliance, because of the extension of the appliance.

4.6.2 Installation and finishing

For installation and finishing the following points are of interest:

H = moldings (fig. 2.4 and 2.7)

I = distance profile (fig. 2.4)

J = upper side flange combustion chamber (fig. 2.5)

K = distance holder/glass support (fig. 2.6)

L = distance holder/glass support (fig. 2.6)

> **Please note:**

Ensure that the fire is not load-bearing with regard to the false chimney breast.

4.6.3 Method I with cover strip (fig. 2.2)

Build the false chimney breast or plateau against the moldings H and distance profiles I (see fig. 2.4 and 2.7).

Keep a minimum distance of 2mm between the false chimney and the appliance, because of the extension of the appliance. **Take into account the thickness of the finish!**

4.6.4 Method II with built-in strip (fig. 2.3)

Remove the distance profiles "I" (see fig. 2.4).

Make sure that the screws of the front distance profile "I" will be replaced, in order to ensure the air tightness of the appliance.

Build the plateau against the glass supports K and L (see fig. 2.6).

Keep a minimum distance of 2mm because of the extension of the appliance.

For the height of the plateau see point "J" (fig. 2.5).

5 Removing the glass

5.1 Removing the glass from the front

MatriX 450-I:

- Remove the moldings "A" left and right (fig. 3.0).
- Turn the left and right side clamps "B" up (fig. 3.0).
- Place the suction cups on the glass and slide the upper list "C" up (fig. 3.1).
- See fig. 3.2, number:
 1. Slide the glass to the top so that the bottom will release.
 2. Now, carefully slide the glass to the left.
 3. Get the released side towards to you and put the glass on a safe place.

MatriX 450-II:

- Remove molding "A" left or right (fig. 3.0).
- Turn the left or right side clamps "B" up (fig. 3.0).
- Place the suction cups on the glass and slide the upper list "C" up (fig. 3.3).
- See fig. 3.3, number:
 1. Slide the glass to the top so that the bottom will release.
 2. Now, carefully slide the glass to the left or to the right.
 3. Get the released side towards to you and put the glass on a safe place.

MatriX 450-III:

- Place the suction cups on the glass and slide the upper list "C" up (fig. 3.3).
- See fig. 3.3, number:
 1. Slide the glass to the top so that the bottom will release.
 4. Get the released side towards to you and put the glass on a safe place.

5.2 Removing the glass from the side

It is not necessary to take out the glass from the side to place the log set or for maintenance.

MatriX 450-II en -III:

- First, remove the front glass (see Chapter 5.1).
- Remove the left or right clamp strip on the top (fig. 3.4).
- Place the suction cups on the glass (fig. 3.5).
- See fig. 3.5, number:
 1. Slide the glass towards to you and to the top so the bottom and back side will release.
 2. Now, carefully get the underside towards to you and put the glass on a safe place.

> **Please note:**

Replace the glass in reverse order.

Clean all fingerprints on the glass; otherwise they will burn in once the fire is used.

6 Placing the decoration material

It is not permitted to use other or to add more material in the combustion chamber.

Keep the pilot light always free of decoration material!

See fig. 4.0 to 4.5 or the included log set card:

- Divide the glass granulate on the perforated bottom plate.
- Place the 2 large wood blocks and make sure there is no glass granulate underneath.
- Place the other wood blocks.
- Divide the chips on the glass granulate and the perforated bottom plate.
- Start the fire as described in the user manual.
- Assess whether the flame distribution and the Symbio-effect is good. Move or remove any chips/glass granulate to a good Symbio-effect.
- Replace the glass (Chapter 5) and check the fire image.

7 Checking the installation

7.1 Checking the main burner ignition, pilot flame Ignite the fire as described in the user manual.

- Check that the pilot flame is well above the main burner and not covered by chips.
- Check the ignition of the main burner on full and small setting. (Ignition must be smooth and quiet).

7.2 Checking for gas leaks

Check with a gas leak finder or spray all connections and pipes for gas leakage.

7.3 Checking the burner pressure and primary pressure

Check that the burner pressure and primary pressure match with the information listed in the manual, Chapter 14 "Technical specifications".

Measuring the primary pressure:

- Close the shut-off valve.
- Turn measuring nipple B (see fig. 1.7) some turns open and connect a measuring hose to the gas regulator.
- Take this measurement at highest setting of the fire and when the fire is set to pilot light.
- Do not connect the unit if the pressure is too high.

Measuring the burner pressure:

Check the burner pressure only with proper primary pressure.

- Turn measuring nipple A (see fig. 1.7) some turns open and connect a measuring hose to the gas regulator.
- The pressure must correspond to the value indicated in the technical specifications of this manual. In case of deviation contact the manufacturer.

> **Please note:**

Close all pressure measuring nipples and check for gas leakage.

7.4 Checking the flame image

Let the fire burn for at least 20 minutes at highest setting and check the flame for:

- * Flame distribution
- * Color of the flames

If one or both points are not acceptable then check:

- The log set layout and/or the amount of glass granulate/chips on the bottom plate.
- The pipe connections for leaks (in case of blue flames).
- Whether the correct flue restrictor is fitted. (see fig. 2.0 F, first remove hatch "G").
- The outlet.
 - Wall terminal right side up
 - Roof terminal on the right position
 - If the maximum horizontal flue lengths is not exceeded.

7.5 Flue gas analyzer

If you are in possession of a CO/CO₂ flue gas analyzer, then it is possible to check the supply air and the combustion gases.

There are two measuring pipes at the front of the fire between the mounting frame and the glass (fig. 2.1).

The ratio CO₂ and CO must not be greater than 1:100.

Example:

CO₂ is 4% and CO is 400ppm, measured at the highest point.

If the ratio is greater than 1:100 or exhaust gases are measured in the supply air, then also check above points.

8 Instructions for client

- Recommend that the unit should be checked annually by a qualified specialist to ensure the safe use and to guarantee a long service life.
- Give advice and instructions on care and cleaning of the glass. Highlight the danger of burnt-in fingerprints.
- Instruct the customer on the operation of the appliance and the remote control, including setting the receiver.
- Hand over to customer:
 - installation manual
 - user manual
 - log set instruction card
 - suction cups

9 Annual maintenance

9.1 Checking and cleaning:

- * Check and clean if necessary after verification:
 - the pilot light
 - the combustion chamber
 - the glass
 - the logs for breakage
 - the outlet
- * Replace, if necessary:
 - chips/glass granulate

9.2 Cleaning the glass

Most deposits can be removed with a dry cloth. Clean the glass with a ceramic hob cleaner.

> **Please note:**

Avoid fingerprints on the glass. These are no longer removable after they are burnt in!

Now carry out check-up as described in Chapter 7 "Checking after installation".

10 Conversion to other gas type

The conversion to a different gas type may only be performed by a qualified installer/dealer.

10.1 Conversion from natural gas to propane (or vice versa)

This can only be done by replacing the burner. To do so, please contact your dealer.

Specify with your order always the type and serial number of the device.

11 Flue calculation

A simple way to calculate whether the exhaust configuration is possible in combination with your fire, use the free "Faber Flue App" and download it from:

INTERNET:

BlackBerry, Android, PC (with Google Chrome browser)

APP store:

iPhone, iPad and Mac.

Google Play:

Android smartphones and Android tablets.

Alternatively use the exhaust calculation table (see chapter 13).

The alternatives of outlet lengths and any restrictors are set out in the restrictor table. In the table we work with start length (STL), total vertical height (TVH) and total horizontal length (THL).

- **Start length (STL):**
This is the first part that is placed on the fire and represents a certain value (fig. 12.1, 12.2 and 12.3 A, N and F). This value is in the top row of the table (see restrictor table 11.1 and 11.2).
- **Total vertical height (TVH):**
TVH is the difference in height measured from the top of the unit to the outlet; it can be measured or determined from the building plan. For clarification see the TVH indication in the drawings (fig. 12.1, 12.2 and 12.3).
- **Total horizontal length (THL):**
THL is the total horizontal length and consists of elbows and pipes which are entirely in the horizontal plane. Elbows I, K and Q and the elements H, J, L, M, P and R (fig. 12.1 and 12.2).
- **Length horizontal plane:**
The horizontal length consists of the elements H, J, L, M, P and R (fig. 12.1 and 12.2).
- **Elbows 90° in the horizontal plane:**
Horizontal bends are bends which are entirely in the horizontal plane (fig. 12.1, 12.2 and 12.3 I, K and Q).
- **Bends 45° or 30° in the horizontal plane:**
Horizontal bends are bends which are entirely in the horizontal plane.
- **Elbows 90° vertical to horizontal plane:**
These are 90° elbows, which proceed from horizontal to vertical (fig. 12.2 and 12.3 G, O and S).
- **Bends 45° or 30° vertical to horizontal plane:**
These are 30° or 45° bends with a vertical offset of less than 45° (fig. 12.1 B and D).

- Pipes under a tilt angle:

These are pipes which are vertically ascending at an angle of 30° or 45° (fig. 12.1 C). Fill in only in combination with at least 2x 30 or 45° bends in the vertical part.

- Restrictor table:

See the restrictor table at the right vertical (TVH) and horizontal length (THL).

For "x" and if the values are outside the table, then the combination is not allowed. Only then adjust the TVH or THL.

If a value is indicated, check that the calculated STL value is not lower than indicated in the table. In this case STL must be adjusted.

The found value indicates the width of the restrictor ("0" means no restrictor). Standard is a restrictor of 30mm installed (see fig. 2.0 F, first remove hatch "G").

11.1 Restrictor table (100/150) NG MatriX 450/500 – 450/650

Starting length (STL), Vertical (TVH) and Horizontal (THL)

STL	0,1	0,2	0,5	0,5	1	1	1				
THL	0	1	2	3	4	5	6	7	8	9	10
TVH	0	x	x	x	x	x	x	x	x	x	x
	0,5	30,0	x	x	x	x	x	x	x	x	x
	1	40,0	0,0	0,5	0,5	0,5	x	x	x	x	x
	1,5	40,0	0,0	0,0	0,0	0,0	0,5	0,5	x	x	x
	2	45,0	0,0	0,0	0,0	0,0	0,0	0,0	x	x	x
	3	50,0	30,0	0,0	0,0	0,0	0,0	0,0	x	x	x
	4	50,0	30,0	30,0	0,0	0,0	0,0	0,0	x	x	x
	5	50,0	40,0	30,0	30,0	0,0	0,0	0,0	x	x	x
	6	60,0	40,0	40,0	30,0	30,0	0,0	0,0	x	x	x
	7	60,0	50,0	40,0	40,0	30,0	30,0	0,0	x	x	x
	8	60,0	50,0	50,0	40,0	40,0	30,0	0,0	x	x	x
	9	60,0	50,0	50,0	50,0	40,0	30,0	30,0	x	x	x
	10	60,0	60,0	50,0	50,0	40,0	30,0	30,0	x	x	x
	11	60,0	60,0	60,0	50,0	40,0	40,0	30,0	x	x	x
	12	60,0	60,0	60,0	50,0	50,0	40,0	30,0	x	x	x
	13	60,0	60,0	60,0	50,0	50,0	40,0	30,0	x	x	x
	14	60,0	60,0	60,0	50,0	50,0	40,0	30,0	x	x	x
	15	60,0	60,0	60,0	50,0	50,0	40,0	30,0	x	x	x
	16	60,0	60,0	60,0	50,0	50,0	40,0	30,0	x	x	x
	17	60,0	60,0	60,0	50,0	50,0	40,0	30,0	x	x	x
	18	60,0	60,0	60,0	50,0	50,0	40,0	30,0	x	x	x
	19	60,0	60,0	60,0	50,0	50,0	40,0	30,0	x	x	x
	20	60,0	60,0	60,0	50,0	50,0	40,0	30,0	x	x	x
	21	60,0	60,0	60,0	50,0	50,0	40,0	30,0	x	x	x
	22	60,0	60,0	60,0	50,0	50,0	40,0	30,0	x	x	x
	23	60,0	60,0	60,0	50,0	50,0	40,0	30,0	x	x	x
	24	60,0	60,0	60,0	50,0	50,0	40,0	30,0	x	x	x
	25	60,0	60,0	60,0	50,0	50,0	40,0	x	x	x	x
	26	60,0	60,0	60,0	50,0	50,0	x	x	x	x	x
	27	60,0	60,0	60,0	50,0	x	x	x	x	x	x
	28	60,0	60,0	60,0	x	x	x	x	x	x	x
29	60,0	60,0	x	x	x	x	x	x	x	x	
30	60,0	x	x	x	x	x	x	x	x	x	

12 Examples flue materials

fig. 12.1

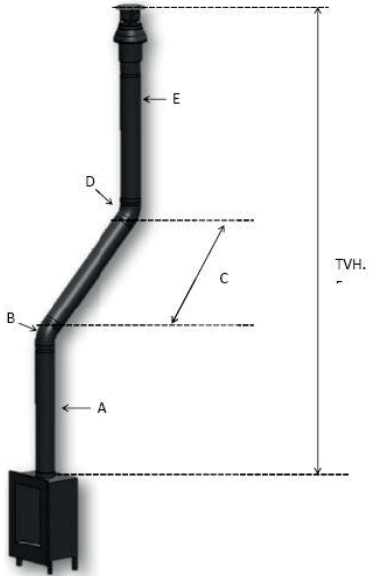

fig.12.2

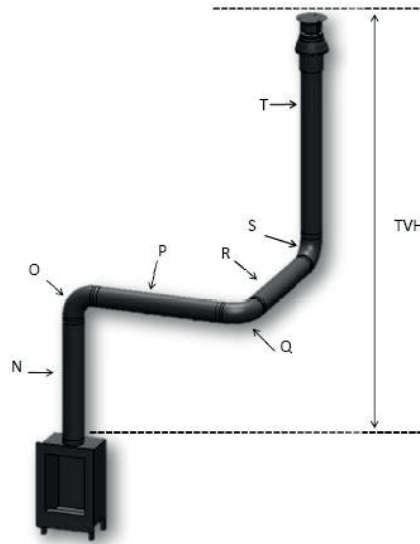
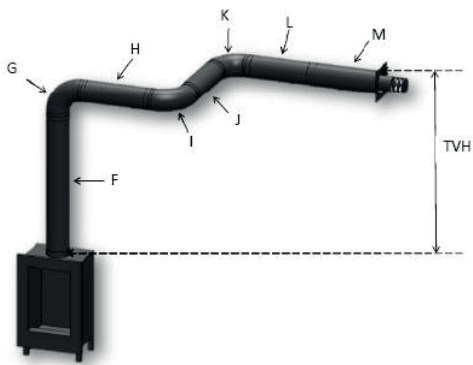

fig. 12.3



13 Calculation sheet

Starter length (STL)				
First part on top of the appliance			Value	
Flue length from 0,1m till 0,45m			0,2	
Flue length from 0,5m till 0,90m			0,5	
Flue length from 1m till 1,4m			1	
Flue length from 1,5m till 2m			1,5	
Flue length 2m or more			2	
Bend 90°			0,1	
Bend 45°, 30° or 15°			0,2	
Roof terminal			1	
Wall terminal			0	
			Value	
			
Total Vertical Height (TVH)				
measured height				rounded value
..... meter			 meter
Total Horizontal Length (THL)				
Calculation				
Part	number	x	value	result
Total Length in meters	x	1
90° Bend, vertical to horizontal	x	0,4
45° Bend, vertical to horizontal	x	0,2
90° Bend in horizontal direction	x	1,5
45° Bend in horizontal direction	x	1
flue pipes at an angle in meters	x	0,7
				rounded value
Total			+ meter

Search in the table at TVH and THL and enter the value that is found.		found value
If the detected value is a number, check whether the completed STL is higher or equal to the value in the table.		
Is the STL value lower as specified in the table then the installation is not possible. Solution: Start length to low, see for the minimum length in the top row of the table.		
Is the found value X, then the installation is not possible. Solution: Change the TVH or THL.		
Results		
Restrictor size = Value for the comma	 mm
Extra information = Value behind the comma		mark
Install the air restrictor plate, see installation manual	0,1	<input type="checkbox"/>
Install adapter 100/150 direct on top of the fire	0,2	<input type="checkbox"/>
In case of wall terminal, install adapter 100/150 before the last bend, incase of roof terminal just before the terminal.	0,3	<input type="checkbox"/>
In case of roof terminal (always size 100/150) install the 100/150 adapter just before the terminal. Wall terminal 130/200	0,4	<input type="checkbox"/>
From the fire first an adjuster to 200/130 and 1 meter 200/130, after that reduce to 150/100 and everything 150/100.	0,5	<input type="checkbox"/>

14 Technical data

14.1 MatriX 450/500 and 450/650

Gas category		I2H
Type appliance		C11/C31/C91
Reference gas		G20
Input Hi	kW	7,3
Efficiency class		1
NOx-class		5
Inlet pressure	mbar	20
Gas rate	m ³ /h	0,800
(at 15° C and 1013 mbar)	gr/h	-
Burner pressure at full mark	mbar	12,4
Injector main burner	mm	(2x) 0,9 (2x) 1,2 (1X) 1,3
Reduced input restraint	mm	1,8
Pilot flame		SIT145
Code pilot flame injector		Nr.36
Diameter outlet/inlet	mm	100/150
Gas controle valve		GV60
Gas connection		3/8"
Electrical connection	V	230
Batteries remote Symax	V	(2x) 1,5 AAA
Batteries remote ITC	V	(2x) 1,5 AA

15 Terminal position

> Please note: These rules apply only for the proper functioning of the unit, for ventilation and environmental protection you need to comply with the applicable rules as defined in the building regulations.

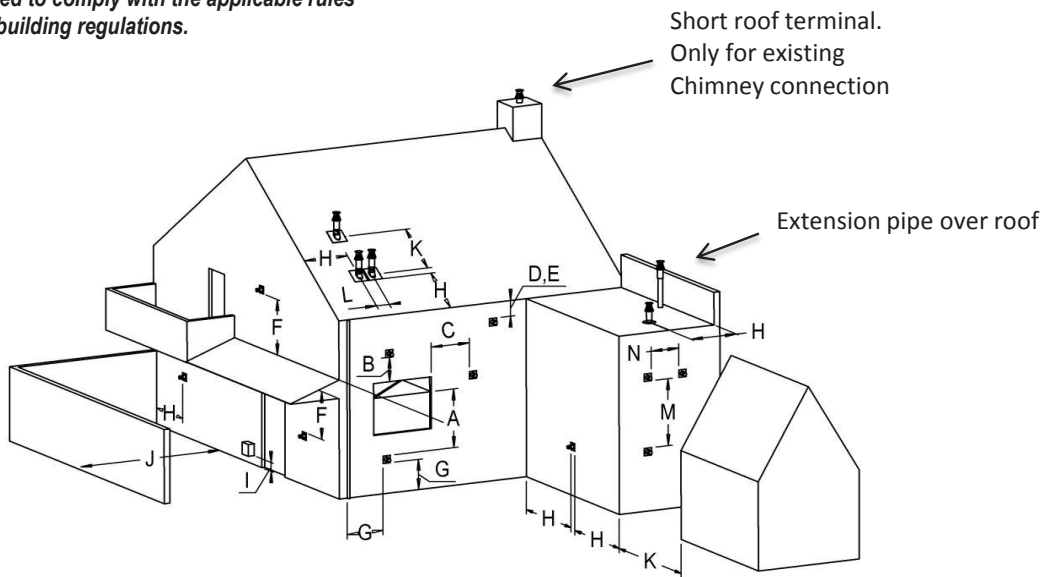

Location	Position outlet	Distance mm
D	Under a gutter	500
E	Under a roof edge	500
F	Under a carport or balcony	500
G	Vertical downpipe	300
H	Inside and outside corners	500
J	From wall surface to a wall outlet	1000
K	Two gable outlets against over each other	1000
L	Distance between two roof outlets	450
M	Two roof outlets above each other on a pitched roof	1000
N	Two gable outlets next to each other	1000

16 Guide de dépannage

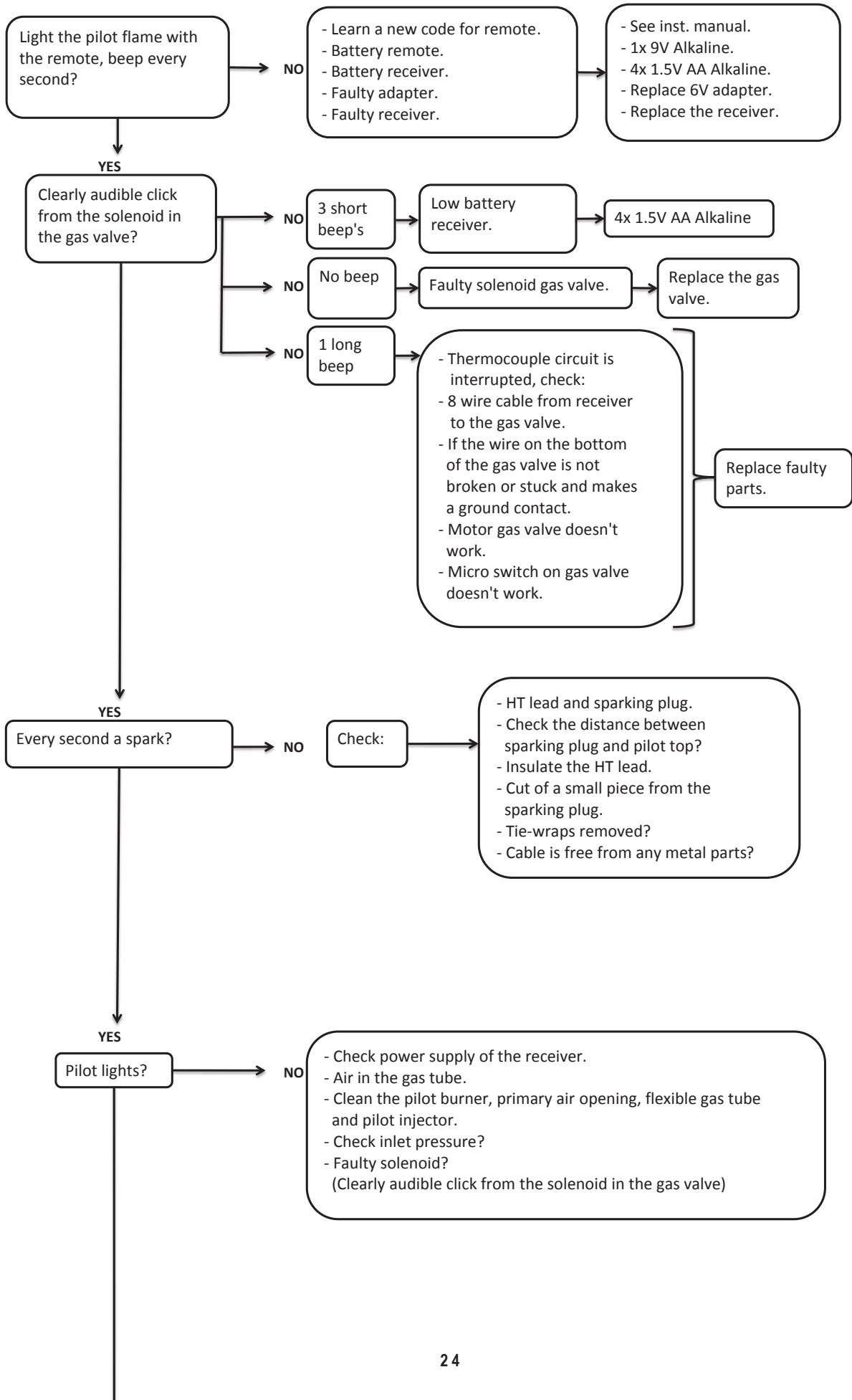

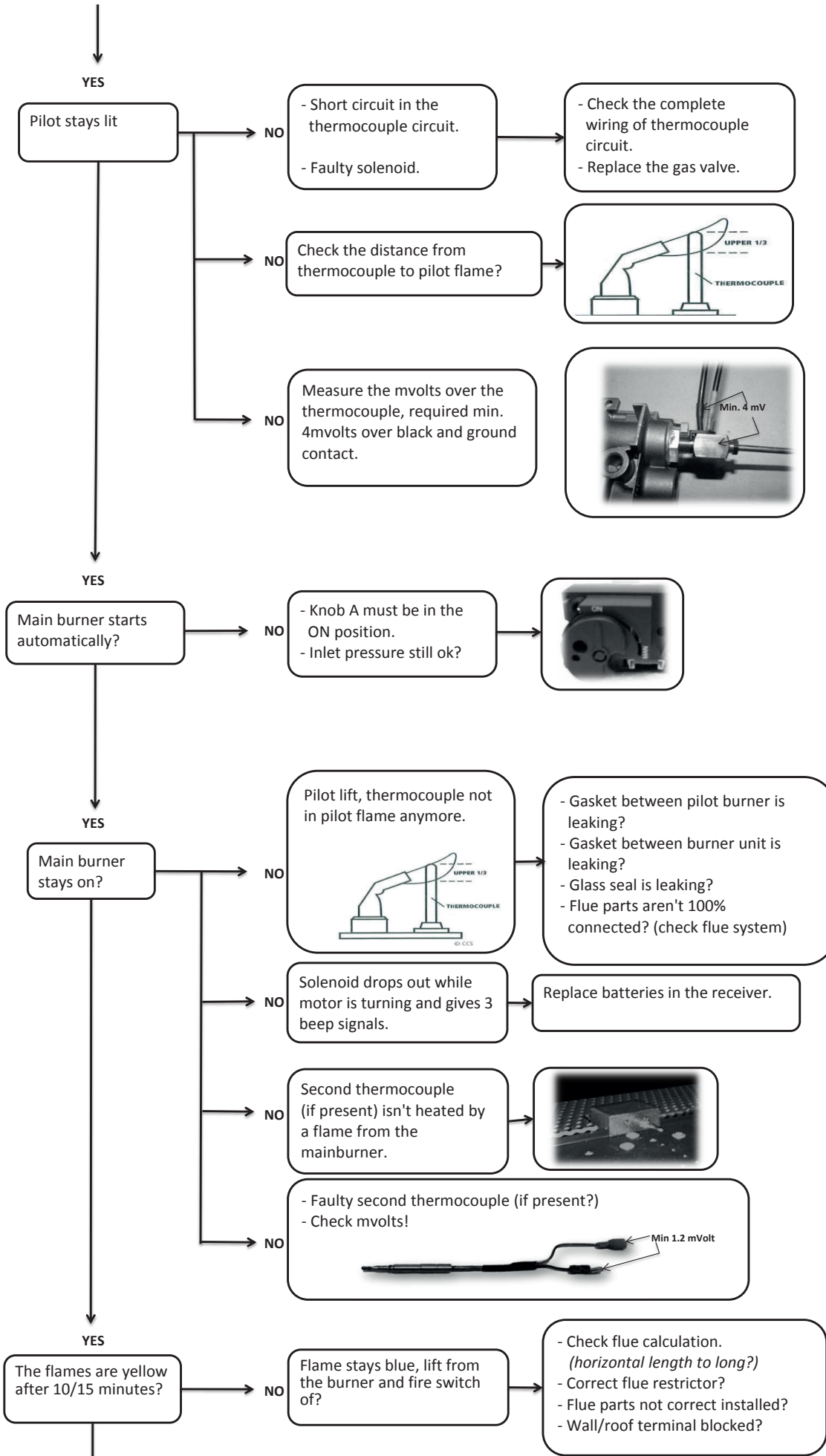

Installation Instructions

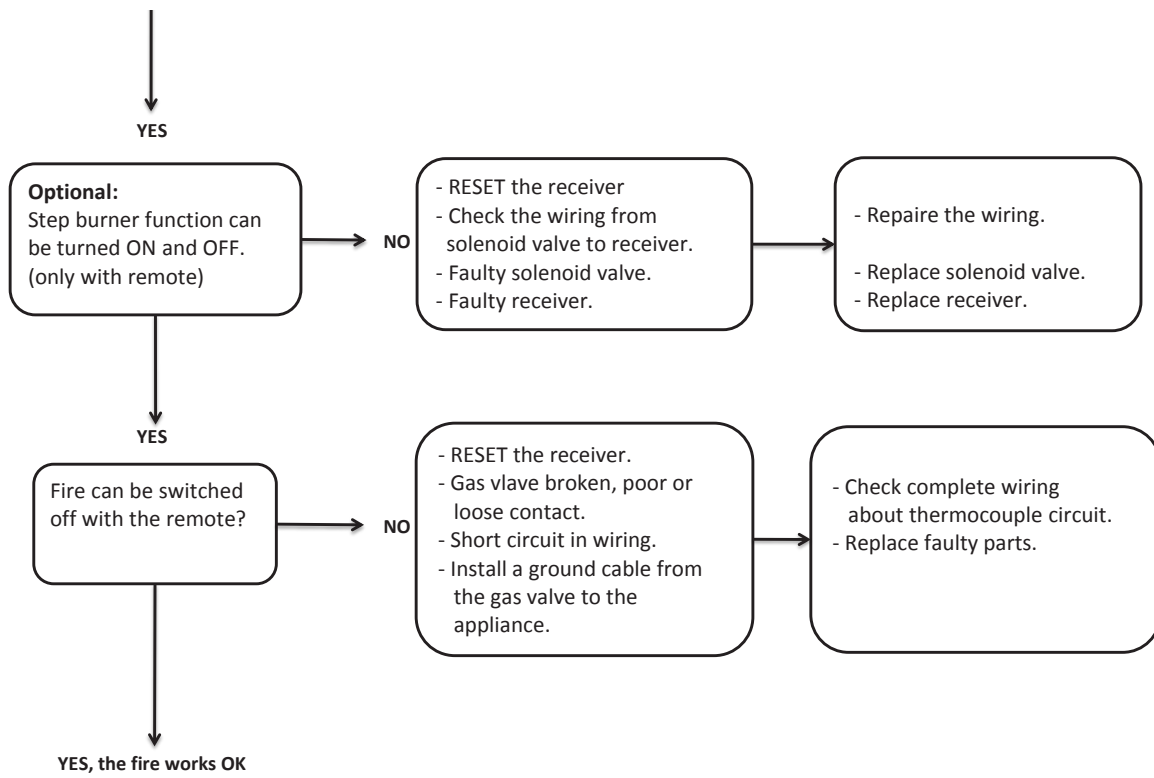

17 Dimensional drawings

17.1 MatriX 450/500-I

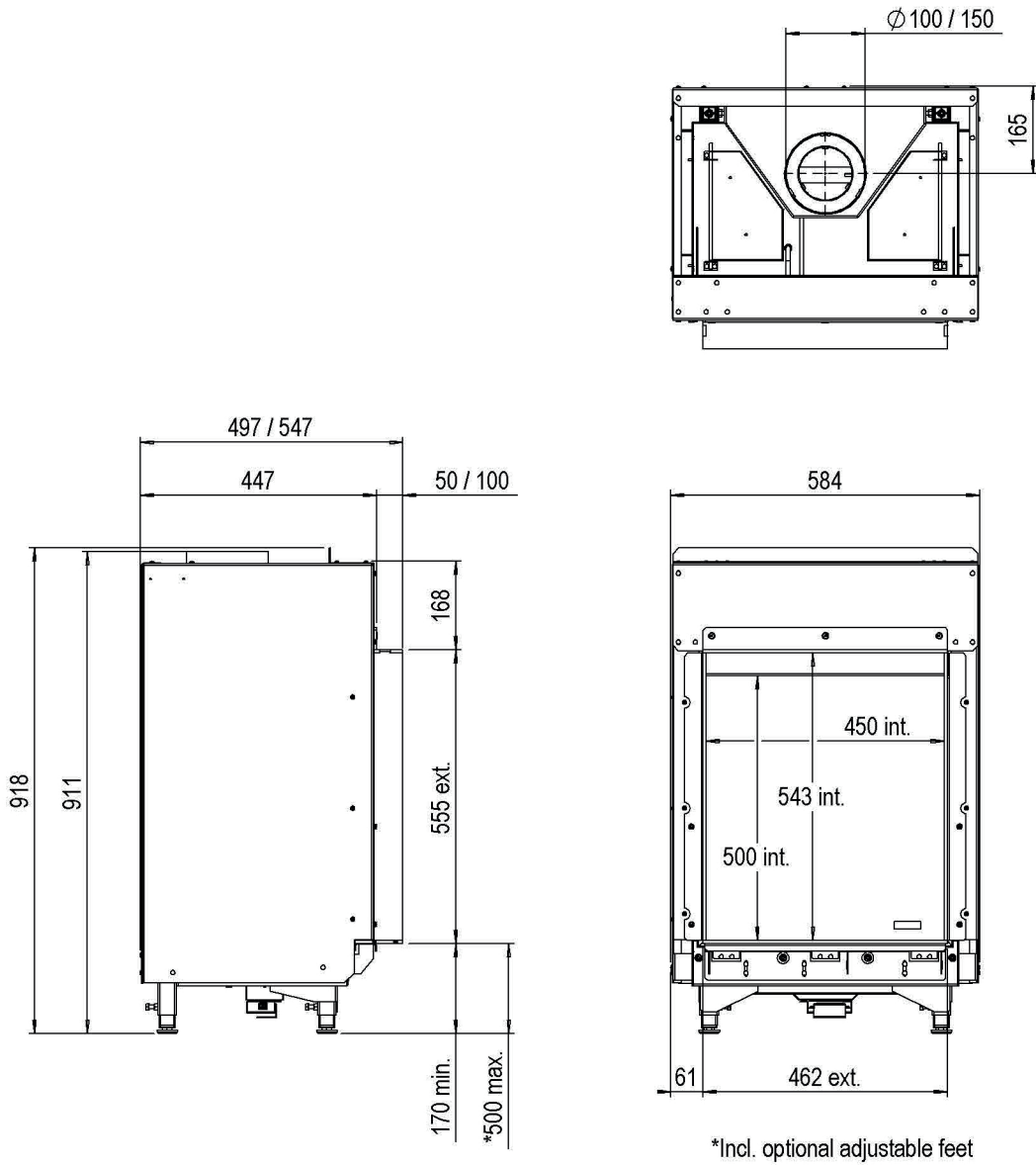

*Incl. optional adjustable feet

17.2 MatriX 450/500-III

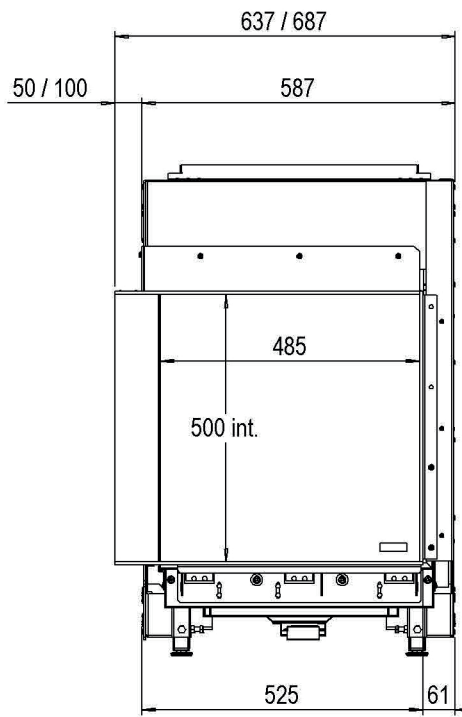
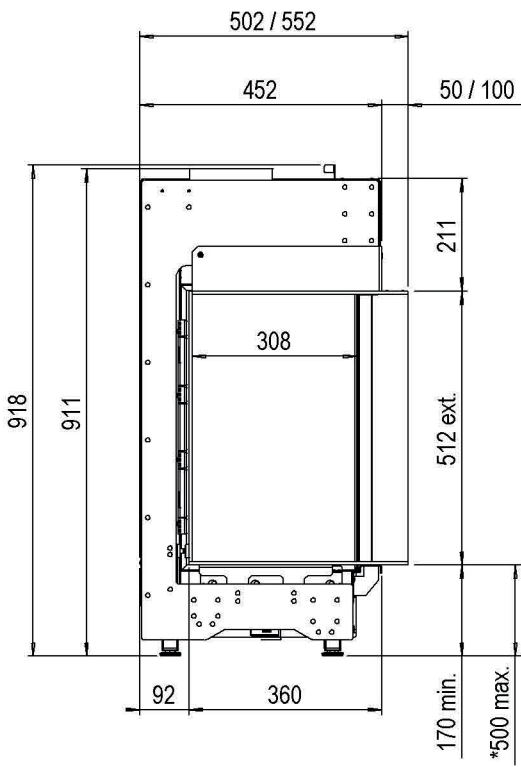
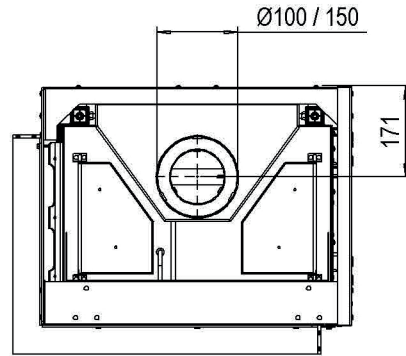

*Incl. optional adjustable feet

17.3 MatriX 450/500-IIR

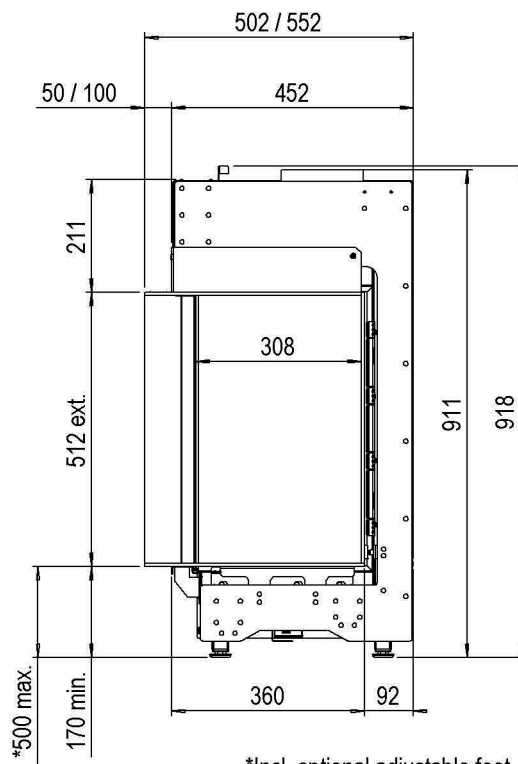
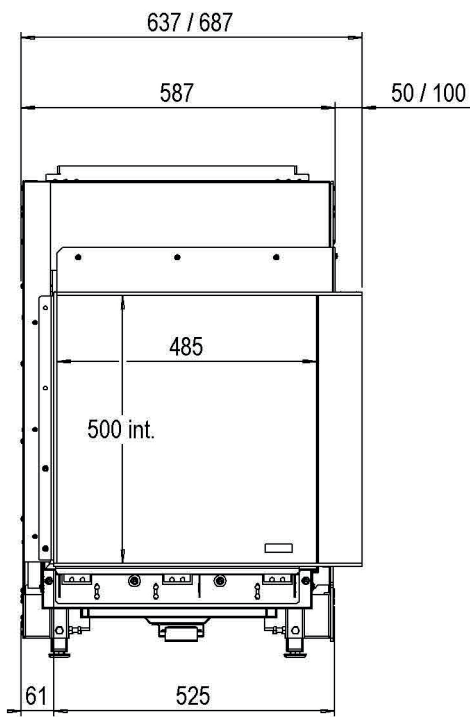
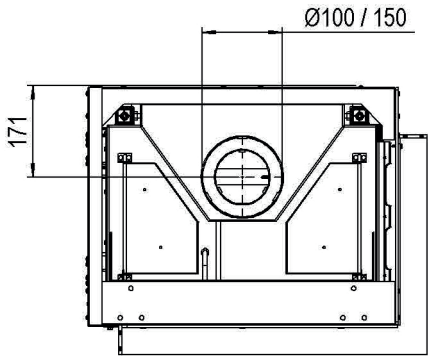

*Incl. optional adjustable feet

17.4 MatriX 450/500-III

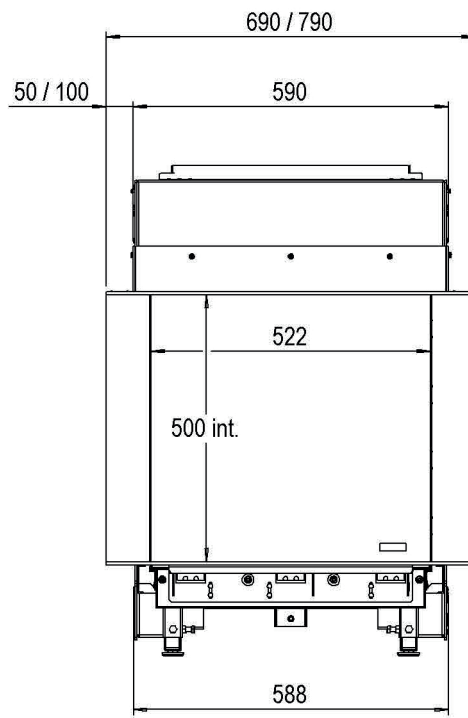
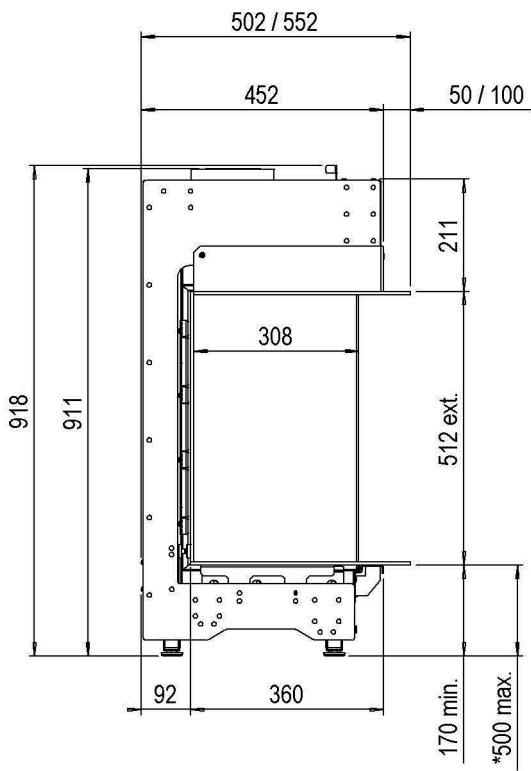
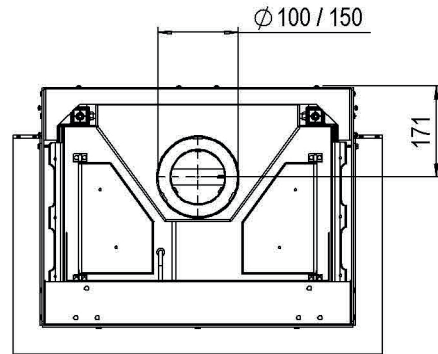

*Incl. optional adjustable feet

17.5 MatriX 450/650-I

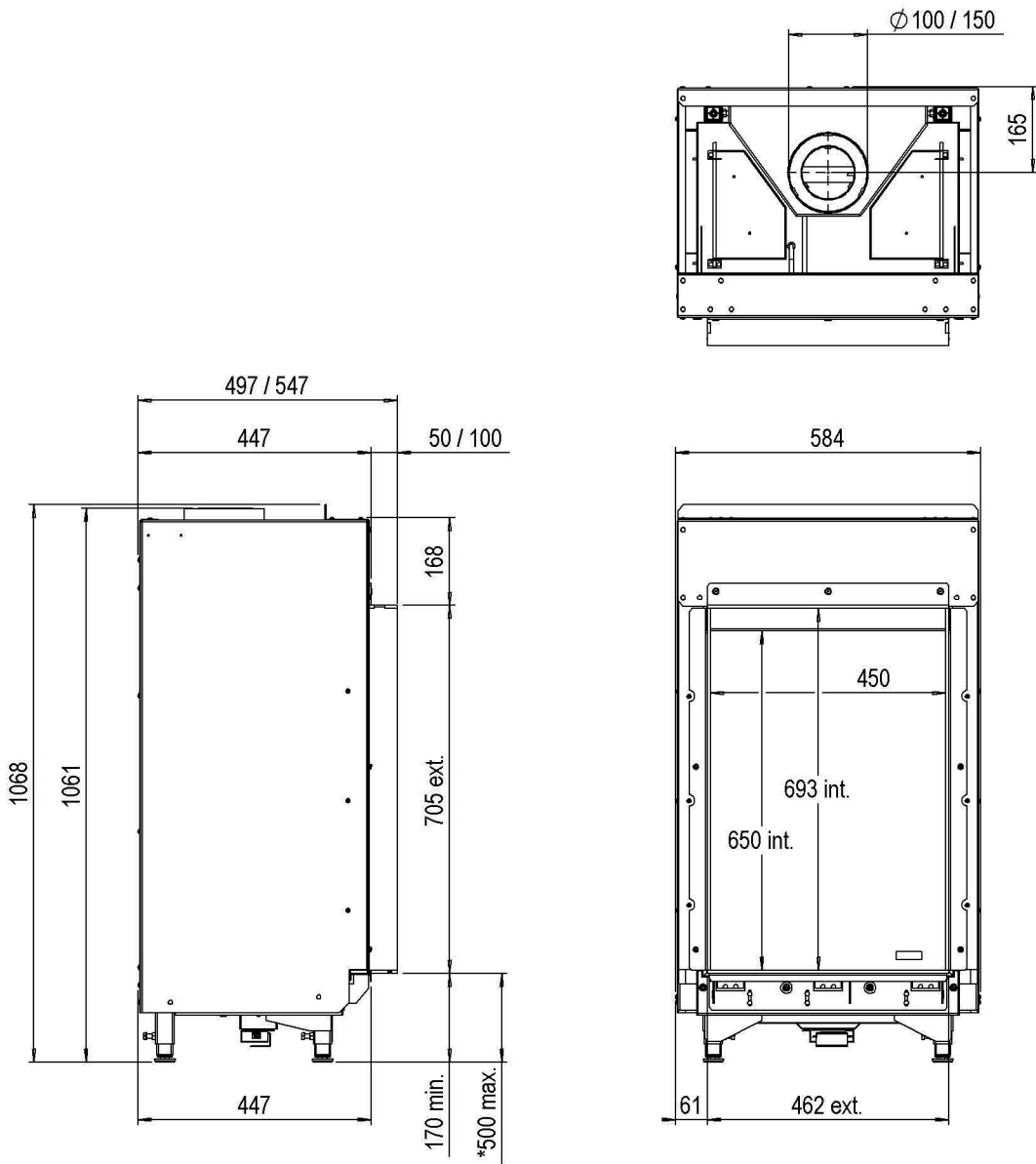

*Incl. optional adjustable feet

17.6 MatriX 450/650-III

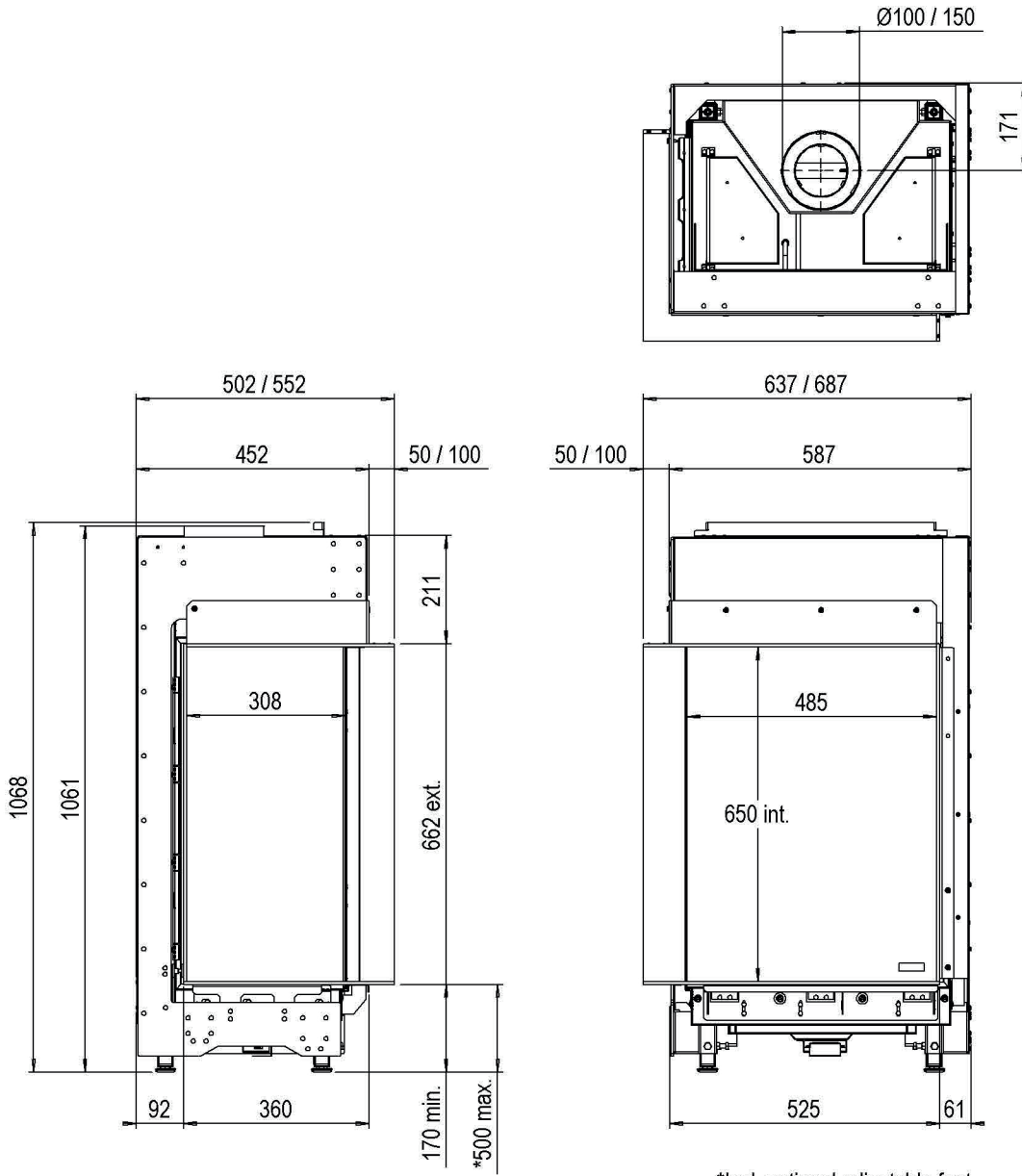

*Incl. optional adjustable feet

17.7 MatriX 450/650-IIR

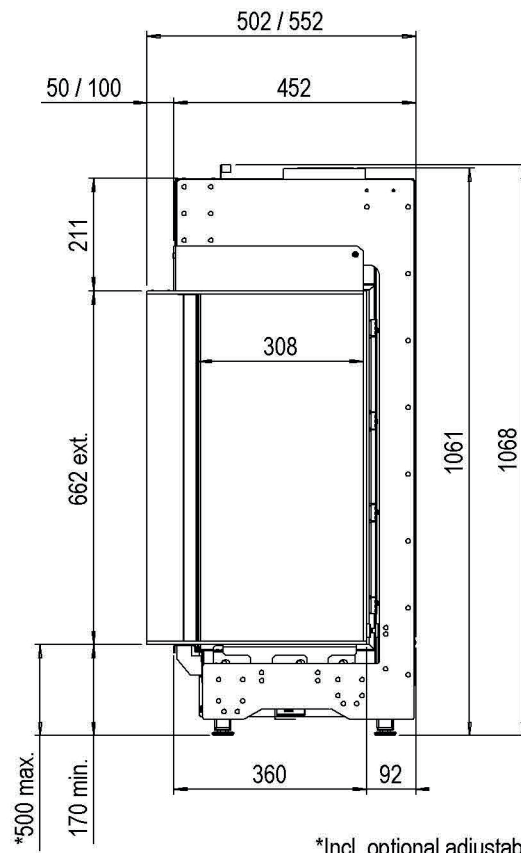
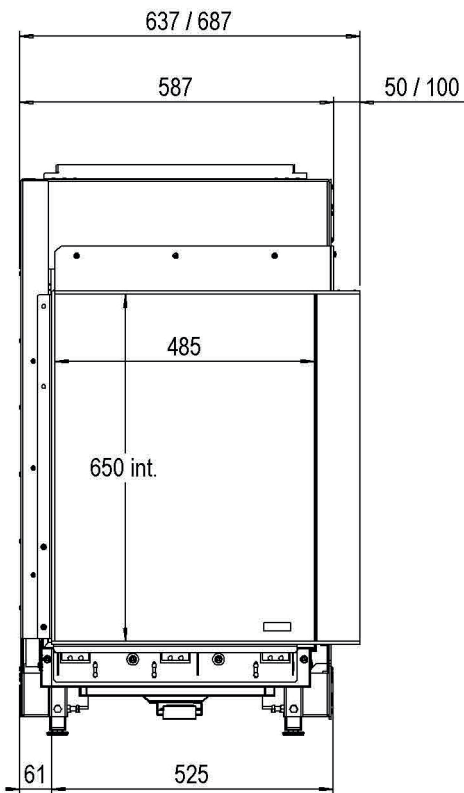
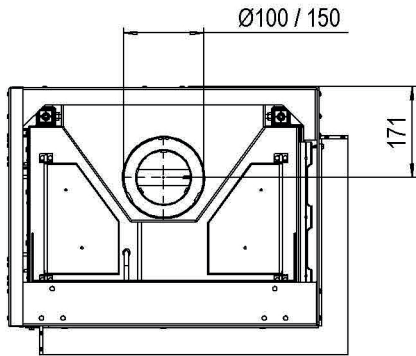

*Incl. optional adjustable feet

17.8 MatriX 450/650-III

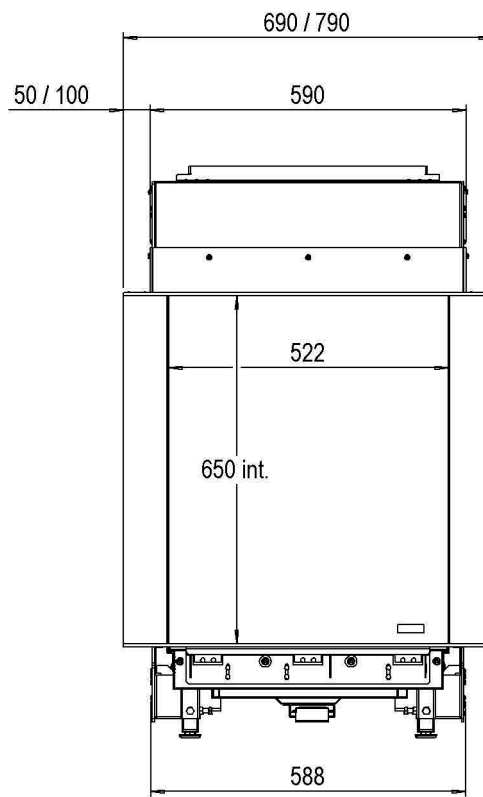
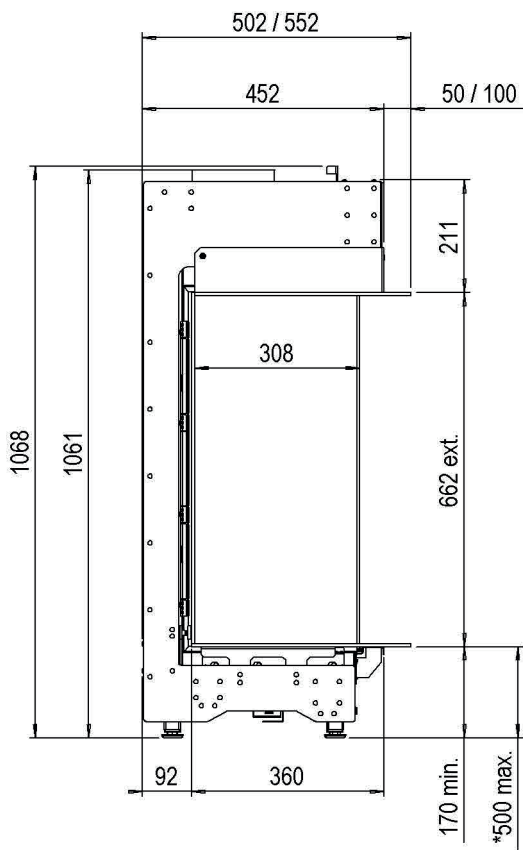
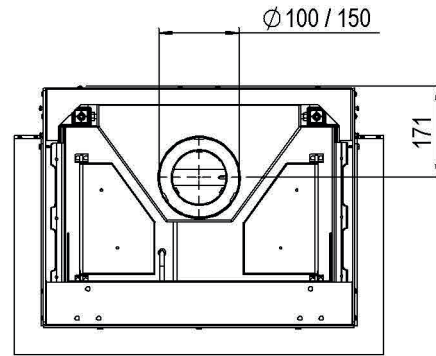

*Incl. optional adjustable feet

17.9 Wall bracket

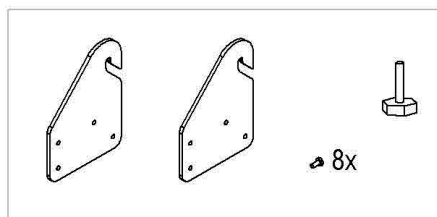
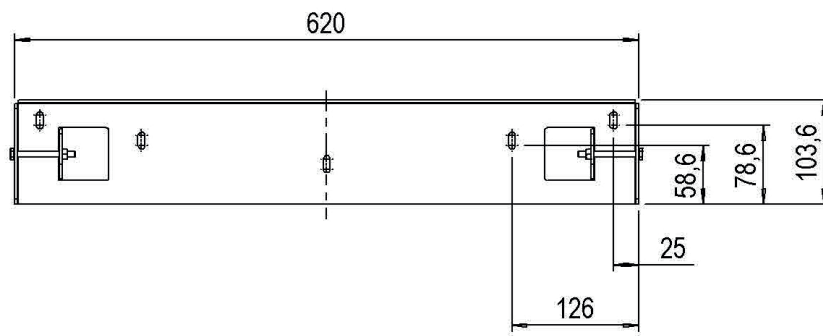
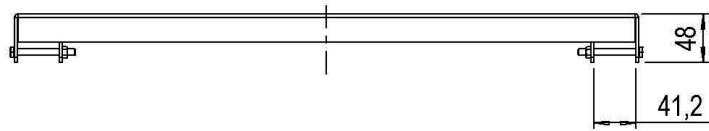
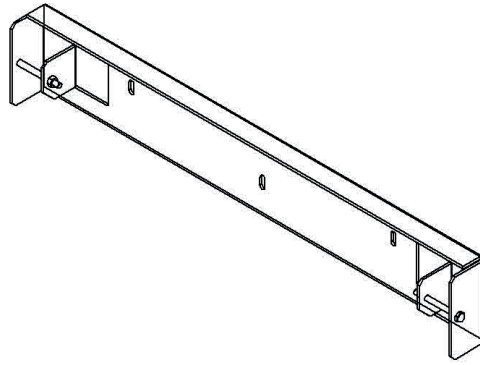

17.10 Remote acces door

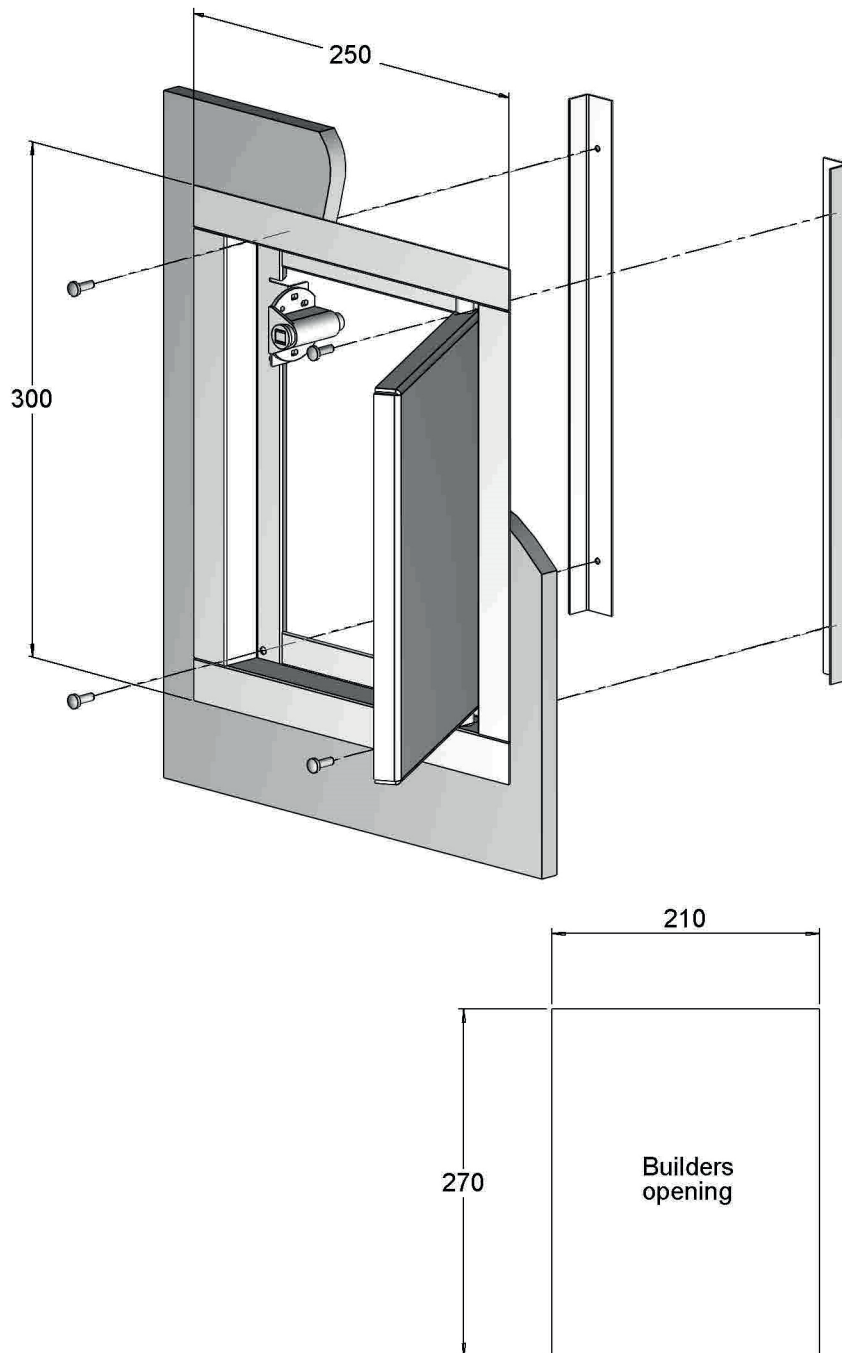

17.11 Ventilation grid

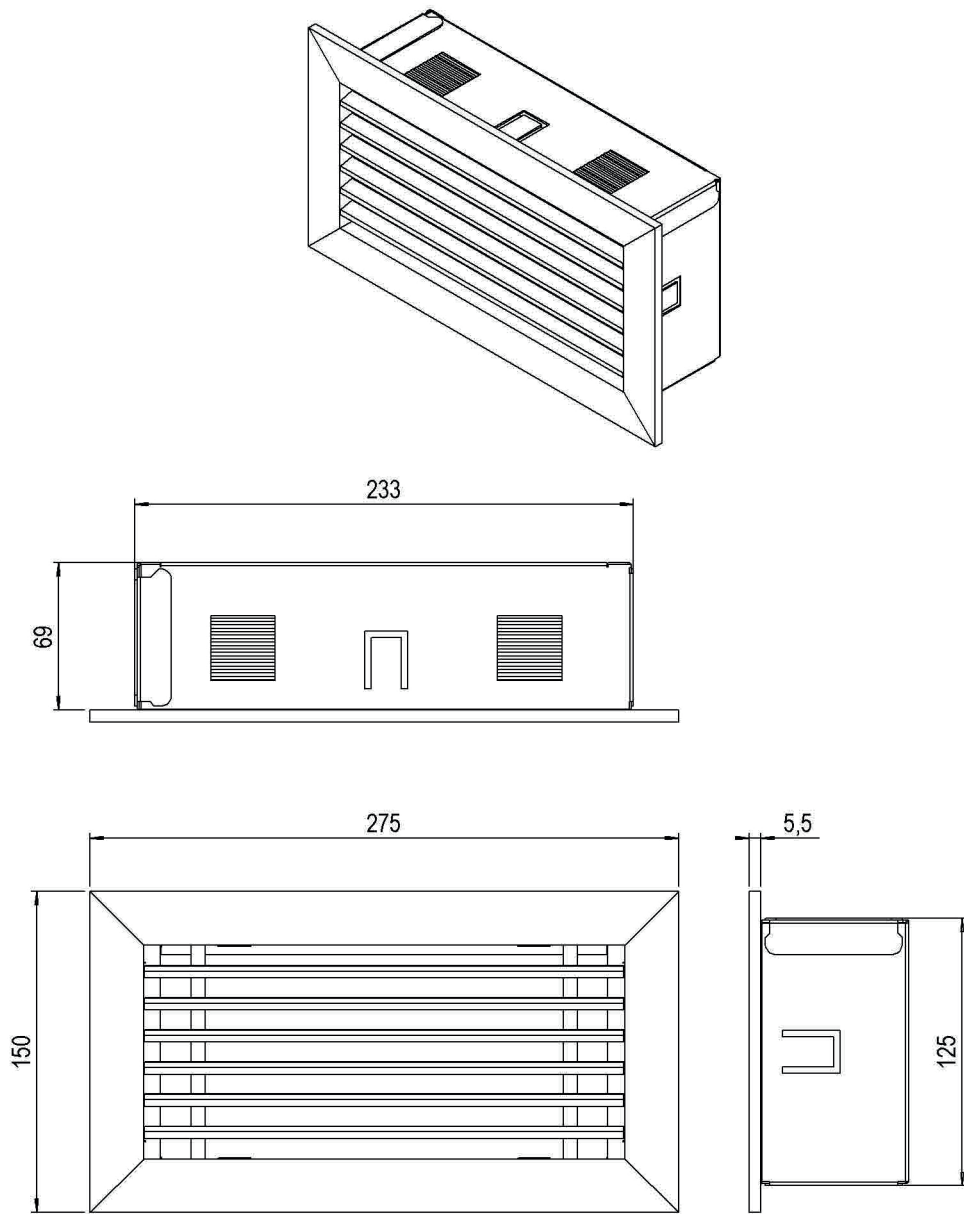

17.12 Adjustable feet

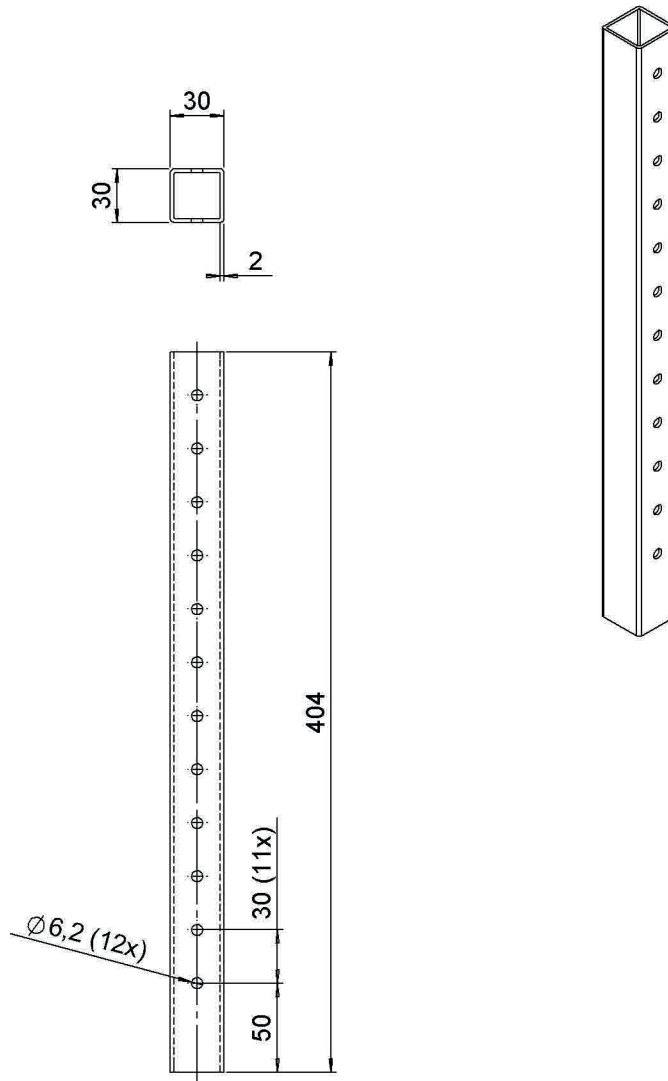



www.faber.nl

info@faber.nl

Saturnus 8
Postbus 219

NL - 8448 CC Heerenveen
NL - 8440 AE Heerenveen

Dealerinfo: